

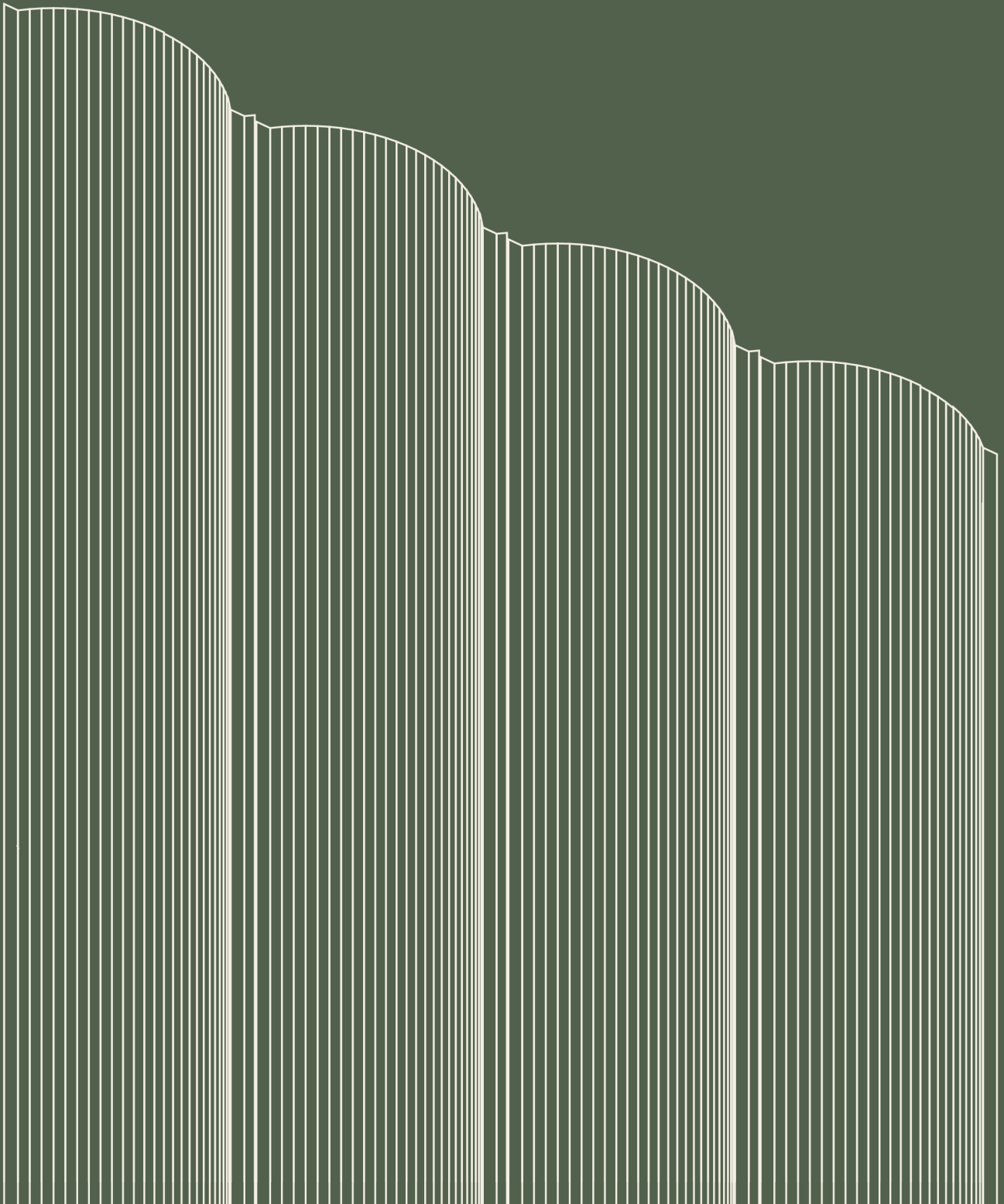

# Brolis Timber cladding installation instructions

Version 1.1 2026



# Turinys

00 Introduction	4
01 Ventilated Façade	5
02 Subframe	7
Supporting structure	8
Air cavity and subframe types	9
Horizontal and vertical battens	10
03 Cladding	12
03.1 Basic installation principles	13
The importance of ventilation and drainage slope	14
End cutting and joining	15
Plinth detail	16
Protection against insects and rodents	17
The face side of cladding	18
03.2 Profiles and cladding orientation	19
03.3 Fasteners and fixing methods	21
Basic fixing principles	22
Installation of MAGDÉ and RŪTA profiles	23
Installation of GRĒTĒ and VAIVA profiles	24
Installation of URTĒ profile	25
Installation of non-grooved cladding	26
Installation of battens	27
04 Architectural design solutions	29
04.1 For vertical cladding	30
Board joining options	32
Board joining options	33
Grooved cladding details	34
Corner finishing with GRĒTĒ and VAIVA profiles	36

Corner finishing with URTÉ profile	37
Non-grooved cladding details	39
Corner finishing with MYKOLAS profile and battens	40
Opening edges design	41
Cladding segment installation	43
BARBORA installation details	46
<b>04.2 For horizontal cladding</b>	<b>49</b>
Board joining options	50
Grooved cladding details profiles	51
Corner finishing with grooved profiles	52
Non-grooved cladding details	54
Corner finishing with non-grooved profiles	55
Opening edges design	56
<b>04.3 Cladding patterns and design possibilities</b>	<b>57</b>
Mix and match	58
MAGDÉ family	59
MYKOLAS family	63
Wood shingles	67
<b>05 Coating and Ageing</b>	<b>68</b>
Outdoor conditions	69
Ageing	70
Coating	73
Coating and maintenance options	75
Storage	76
Limitation of liability	77

00

# Introduction

Brolis Timber cladding installation instructions – a practical guide for your projects based on many years of experience installing wood products, as well as Brolis Timber’s specific findings from completed projects.

Here you will find a full range of recommendations, from general basic knowledge on how to install wooden facades, what frame or fastening method to choose, how to cut or join boards, and what gaps to leave for ventilation, to detailed solutions on how to fasten specific Brolis Timber cladding profiles, as well as edge and corner finishing. We also provide practical scenarios for surface coating and maintenance, as well as inspiring ideas for unconventional façade patterns and architectural diversity.

Enjoy!

Yours, Brolis

01

# Ventilated Façade

# Ventilated Façade

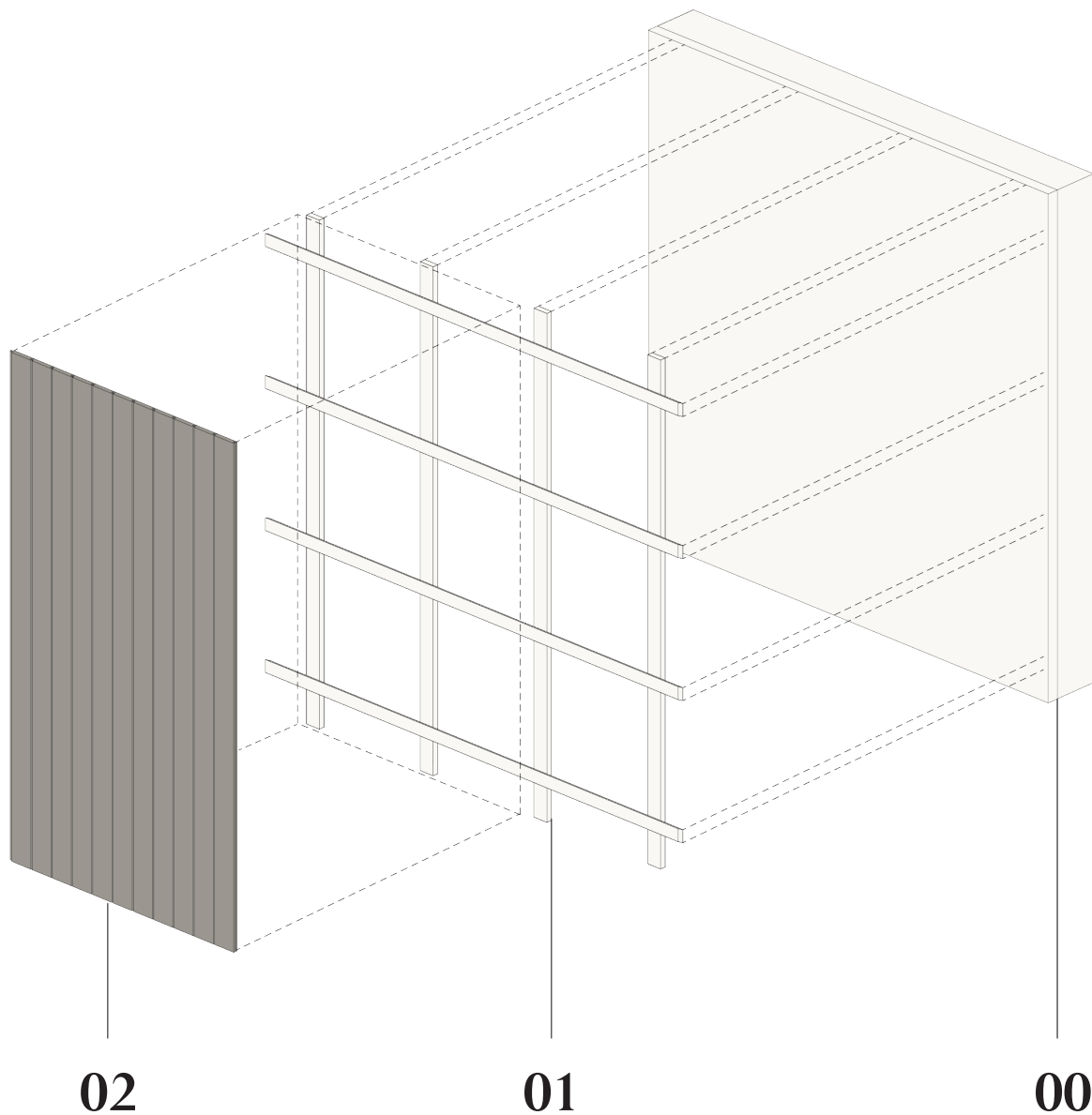

When it comes to wood finishing, make sure you choose a ventilated façade system.

It consists of three main elements:

00 structural support, insulating layer and breathable membrane

01 frame

02 cladding

The external part of the façade (02) creates an aesthetic appearance and protects the façade from precipitation and mechanical impact. The air gap formed with the help of the frame (01) ensures ventilation by helping to remove ambient moisture and condensation forming in the insulation layer. It also prevents the walls from overheating in hot weather.

02

# Subframe

# Supporting structure

Brolis Timber thermo façade can be installed on various types of walls, including masonry, concrete, and timber frame constructions. The most important factors are ensuring proper ventilation on both sides of the cladding surface and using appropriate fastening elements based on the type of supporting structure.

If the supporting structure is made of masonry or concrete and the frame is made of thermo timber, install it spaced away from the supporting wall surface using L-shaped brackets or wood screws with plastic anchors (see Fig. 1). Alternatively, an aluminium profile can be used for the frame (see Fig. 2).

When fixing the frame to a timber-framed wall, screw the vertical battens into the wall's load-bearing elements (see Fig. 3).

If the building is made of CLT or SIP panels, vertical battens can be fixed anywhere except at the edges of panel joints. If fastening is required at a joint, install two vertical battens, one on each side of the joint, leaving  $\geq 150$  mm from the edge (see Fig. 4).

When installing timber subframe and cladding, use stainless steel fasteners.

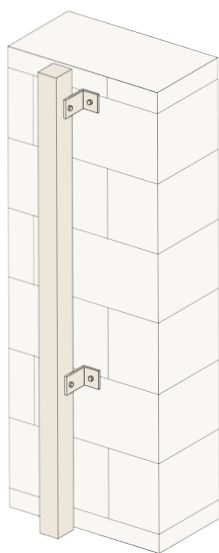

Fig. 1:  
Timber subframe on a  
masonry/concrete wall

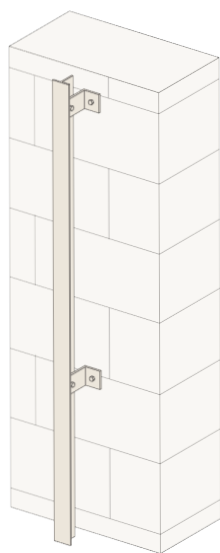

Fig. 2:  
Aluminium subframe on a  
masonry/concrete wall

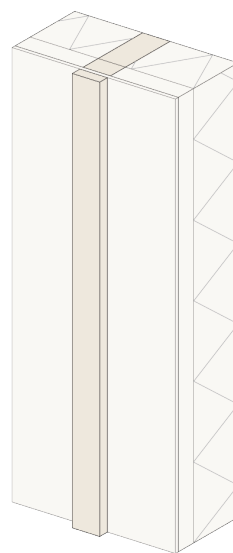

Fig. 3:  
Timber subframe on  
a timber frame wall

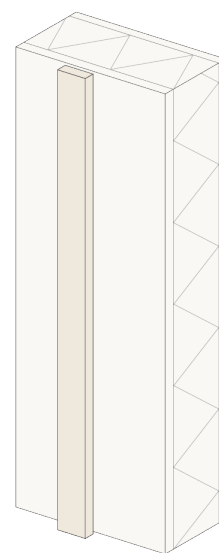

Fig. 4:  
Timber subframe on a  
SIP-type timber wall

# Air cavity and subframe types

The frame not only fastens the cladding but also creates an air cavity necessary for ventilation by separating the exterior finish from the supporting structure. It is crucial that the air can circulate vertically between the cladding and the building wall to prevent moisture accumulation.

Create a consistent ventilation gap of at least 25 mm. In humid climate regions, including Lithuania, it is re-

commended to make this gap larger, around 40 mm. If necessary, this distance can be reduced to 10 mm near window surrounds or other individual building elements.

Before installing the subframe, cover the supporting structure and insulation layer with a breathable membrane to protect the walls from wind and moisture penetration.

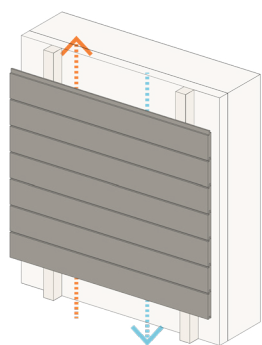

Fig. 1: Single-layer frame when cladding boards are installed horizontally

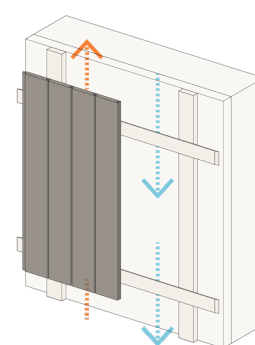

Fig. 2: Double-layer frame when cladding boards are installed vertically

## Subframe type depends on cladding orientation.

When installing the cladding horizontally (see Fig. 1) or diagonally with an inclination angle of  $\leq 45^\circ$  (see Fig. 3), choose a single-layer frame. Vertical battens create an air cavity to ensure proper ventilation.

When installing the cladding vertically (see Fig. 2) or diagonally with an inclination angle of  $\geq 45^\circ$  (see Fig. 4), choose a double-layer frame. The first layer creates the air cavity, while the second layer is used to fasten the cladding boards.

Please note that the type of subframe required for diagonally installed cladding depends on the inclination angle of the boards.

Furthermore, while a 600 mm spacing between subframe batten centres is advised for vertical or horizontal cladding installation, it is recommended to reduce this spacing to 400 mm when installing cladding diagonally.

The first layer of the frame, which is fixed to the supporting structure, should always be installed vertically. The battens must be at least 25 mm thick, with a recommended thickness of 40 mm or more.

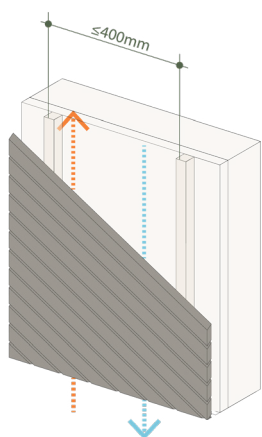

Fig. 3: Single-layer frame when cladding boards are installed at an angle less than  $45^\circ$

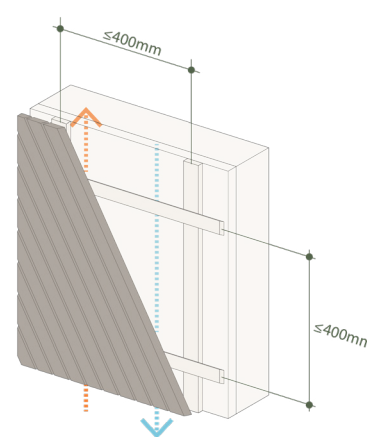

Fig. 4: Double-layer frame when cladding boards are installed at an angle greater than  $45^\circ$

# Horizontal and vertical battens

Vertical battens of the subframe must always be fixed directly to the supporting wall structure (see Supporting structure, p. 8).

Thermo subframe is the best choice for installing thermo cladding due to the consistency of material and physical properties. Fastening cladding boards into wood is significantly easier and faster.

If necessary, aluminium or stainless-steel subframing can also be used. However, keep in mind that wood and metal respond differently to changing weather conditions: during hot periods, wood dries and contracts while metal heats up and expands; conversely, in cold and damp conditions, wood expands while metal contracts. Therefore, when using metal profiles, make sure to include expansion joints spaced no more than 3000 mm apart.

Even if the vertical battens are made of metal, you can choose thermo timber for the horizontal battens. This makes installation easier.

**A.** These Brolis profiles are suitable for wooden frames: for vertical battens – ‘Mykolas’ 26x68 or 26x92, battens 42x42; for horizontal battens – half-rhombus or rhombus profiles in 26x68 or 26x92 (see Fig. 1; 2).

**B.** For aluminium or stainless-steel subframes choose T-shaped profiles (see Fig. 3; 4).

In addition, cladding joints should be planned in advance when installing the frame, as a double horizontal batten must be installed at each joint to provide a fixing point for the ends of the cladding boards.

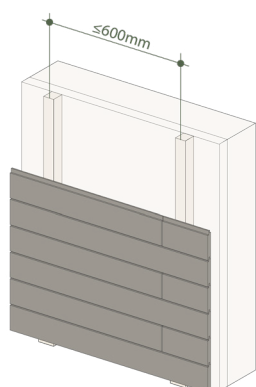

Fig. 1: Single-layer thermo subframe for horizontal cladding installation

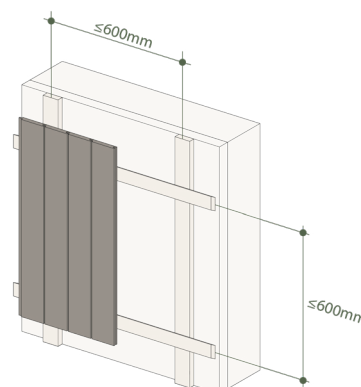

Fig. 2: Double-layer thermo subframe for vertical cladding installation

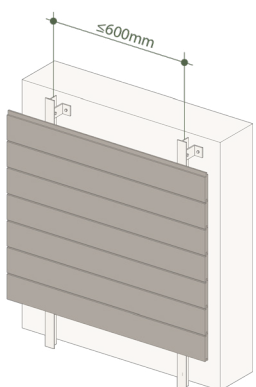

Fig. 3: Single-layer aluminium subframe for horizontal cladding installation

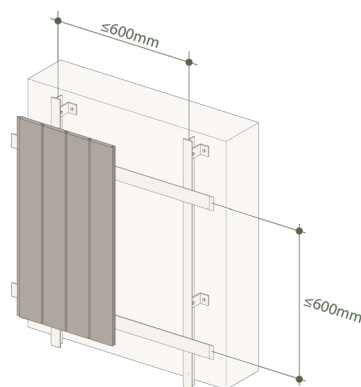

Fig. 4: Double-layer aluminium and thermo subframe for vertical cladding installation



Pasaka Cinema Boutique in Paupys // Vilnius, 2019-2020 // Profiles: Batten 42x68 (façade and roof), batten 42x92 (terrace and benches) // Not coated // Architect: Audrius Ambrasas Architects // Photo: Joana Suslavičiūtė

03

# Cladding

## 03.1

# Basic installation principles

The following essential principles for installing wood products will help ensure a longer service life and an aesthetically pleasing façade, no matter which profile or architectural solution you choose.

# The importance of ventilation and drainage slope

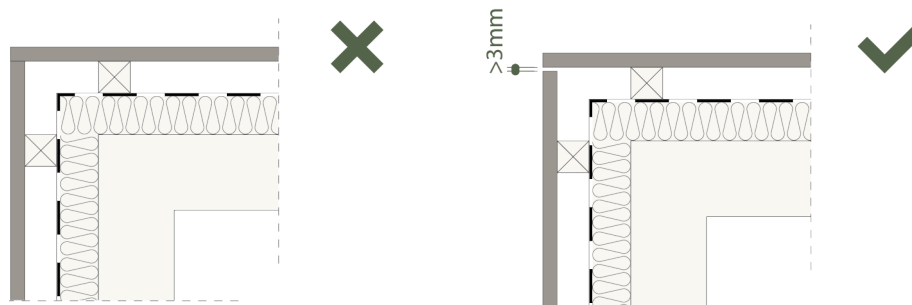

Fig. 1: Leave a ventilation gap at cladding joints

Proper ventilation on all sides of the timber façade is essential to ensure that cladding lasts as long as possible. Therefore, it is important to avoid any water accumulation or moisture retention, especially in areas where the boards come into contact with each other or other surfaces (see Fig. 1; 2).

Avoid any horizontal surfaces where water could accumulate. Furthermore, pay attention to the orientation and profile of the cladding. Boards designed for horizontal cladding should always have a slope to prevent water from pooling and to ensure that precipitation drains quickly from the timber surface (see Fig. 3).

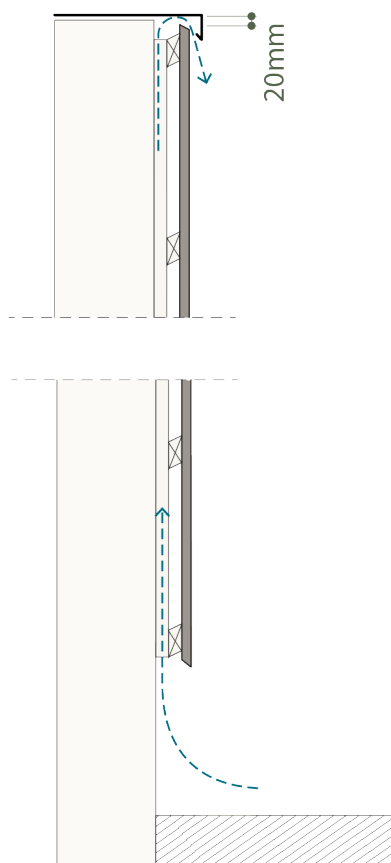

Fig. 2: Proper façade ventilation ensures timber durability

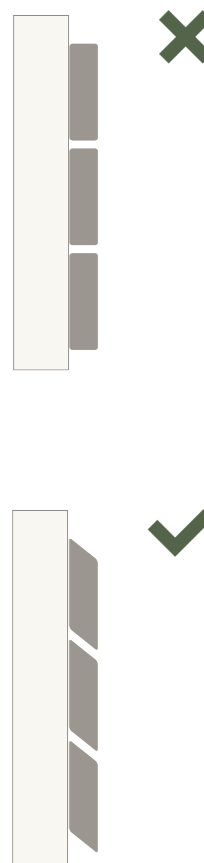

Fig. 3: Avoid horizontal surfaces

# End cutting and joining

When installing vertical cladding, always cut the ends at an angle of at least  $15^\circ$ . This prevents water from collecting on the top edge (see Fig. 1) and creates a drip edge at the bottom (see Fig. 3). Horizontal cladding does not need to be cut at an angle (see Fig. 4).

When installing cladding, always leave ventilation gaps at the ends and joints — at least 20 mm at the top near the parapet (see Fig. 1) and 3 mm or more at cladding joints (or  $\geq 5$  mm when installing in dry and hot conditions; see Fig. 2). These measures allow moisture to evaporate, preventing cladding joints and ends from blackening.

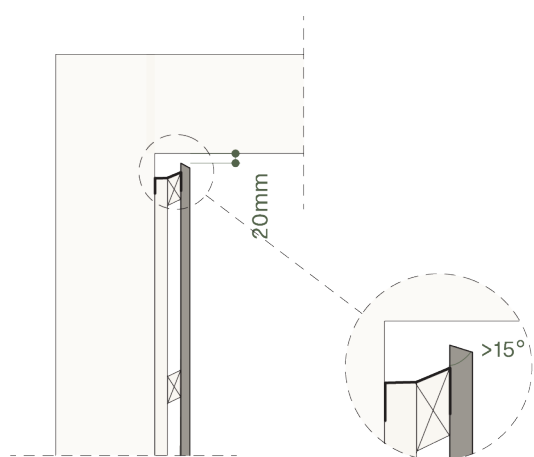

Fig. 1: Top edge detail of cladding with required gap

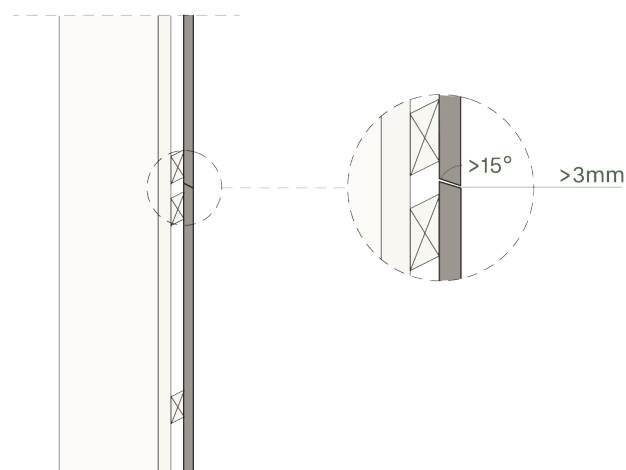

Fig. 2: Joint detail of cladding with a ventilation gap

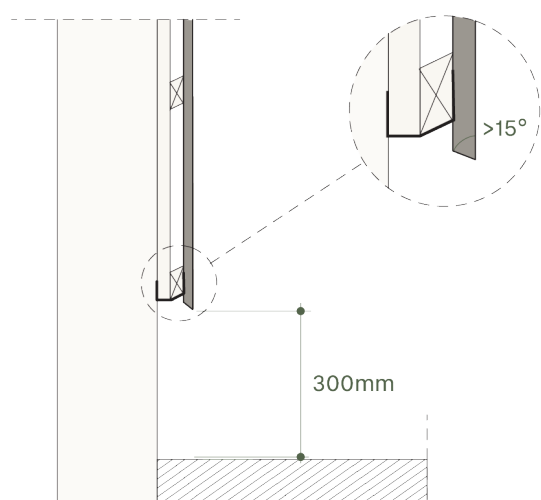

Fig. 3: Bottom edge detail of cladding and the recommended clearance from the ground

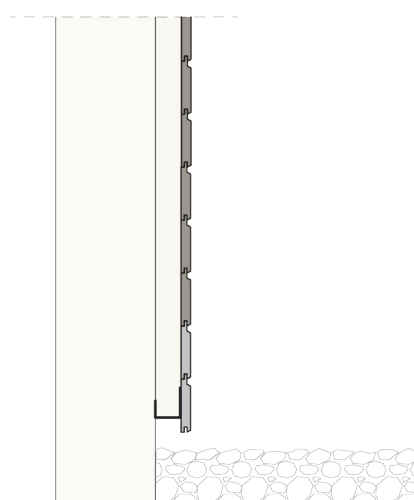

Fig. 4: Horizontally installed cladding does not require angled cutting

# Plinth detail

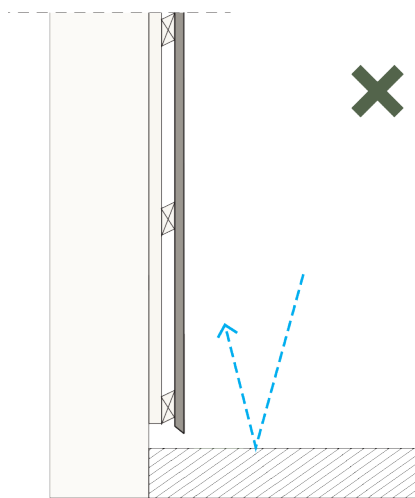

Fig. 1: Cladding should not be installed too close to a horizontal surface

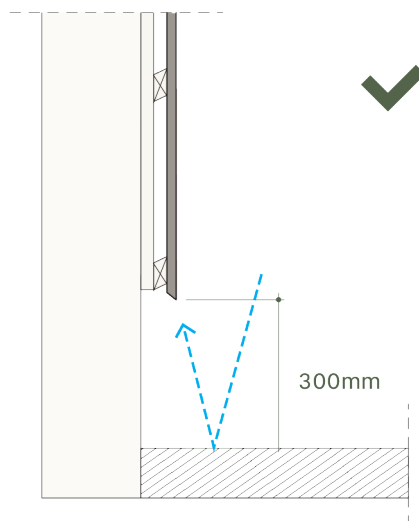

Fig. 2: Clearance between the wooden façade and a solid surface

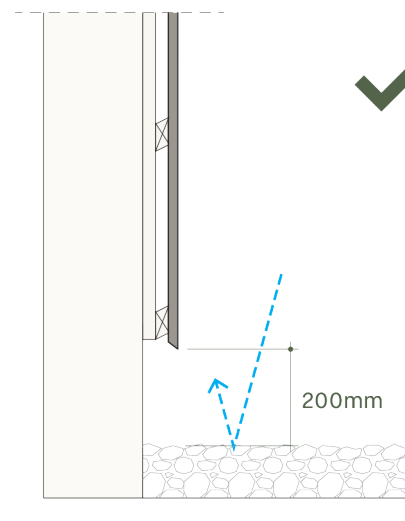

Fig. 3: Clearance between the wooden façade and a permeable surface

Water droplets that bounce off the solid surface splash onto the walls, causing the surface of the lower cladding to darken over time and look untidy. Snow accumulation during winter can also leave marks on the façade (see Fig. 1). For this reason, we recommend installing the cladding raised above the ground (see Fig. 2). Leave a clearance of  $\geq 300$  mm when the surface near the façade is solid (paving stones, concrete, etc. (see Fig. 2)) or  $\geq 200$  mm when the surface is permeable (rubble, gravel, etc. (see Fig. 3)).

These recommendations are less relevant when installing horizontal cladding, as worn lower boards are easier to replace. However, even with this installation method, maintain a minimum clearance of 50 mm from the horizontal surface (see Fig. 4). Please note that the colour of new cladding may initially differ noticeably from previously installed boards.

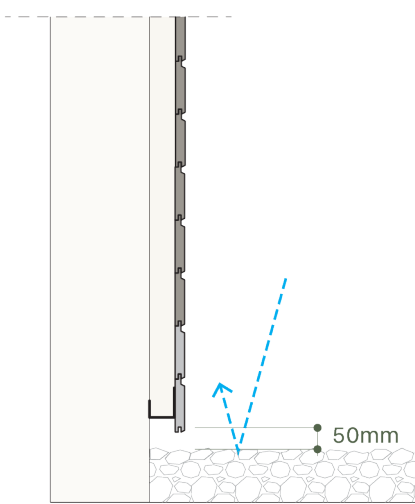

Fig. 4: Required clearance for horizontally installed cladding

# Protection against insects and rodents

To prevent insects and rodents from entering the gap between the cladding and the supporting wall structure, we recommend installing a special protective mesh at the bottom and top of the cladding. The mesh should have a permeability of at least 80%.

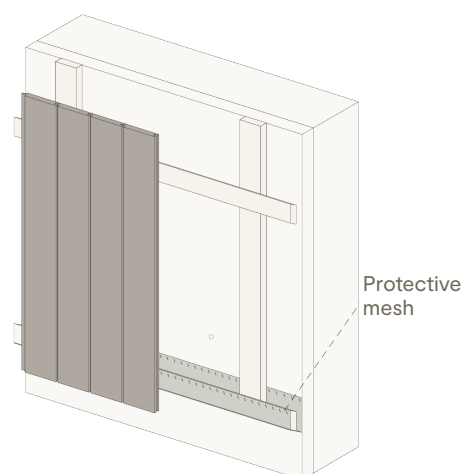

Fig. 1: Protective mesh against rodents and insects

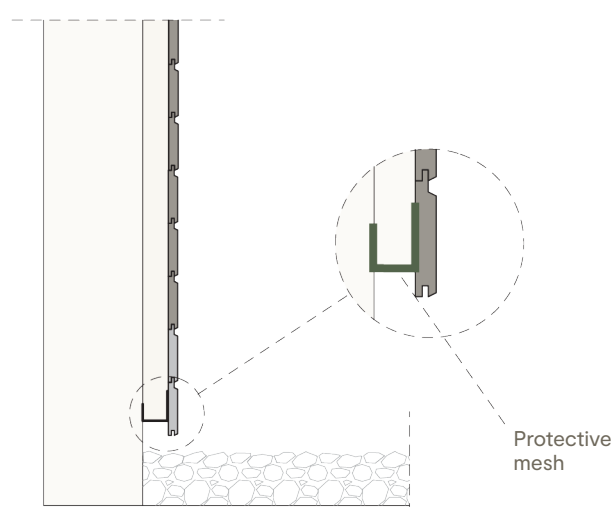
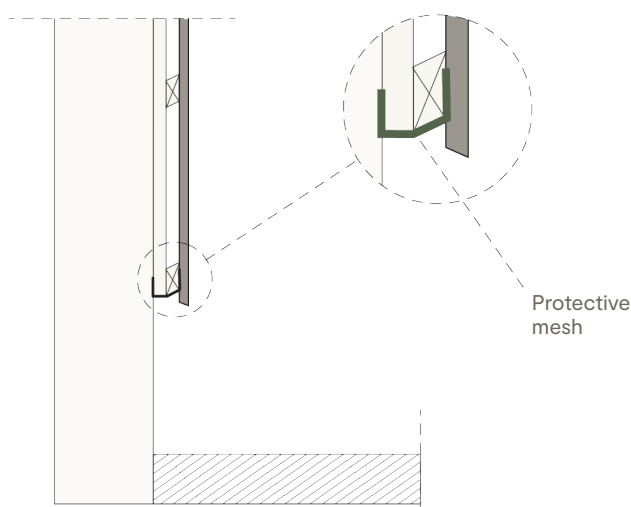
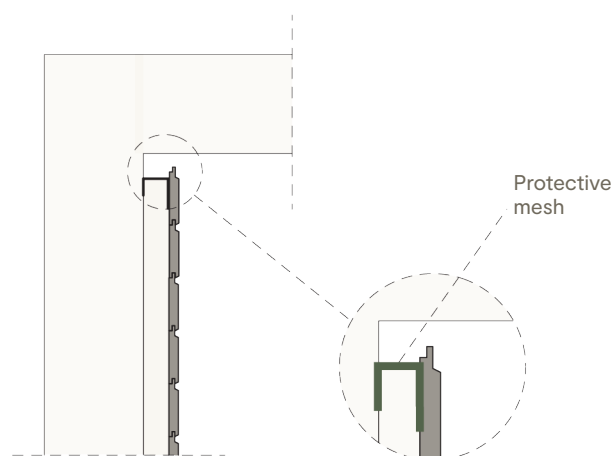
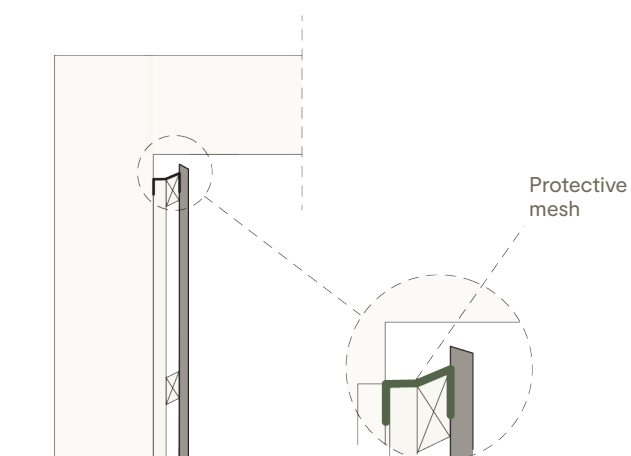

Fig. 2: Protective mesh for vertical cladding on a double-layer frame

Fig. 3: Protective mesh for horizontal cladding on a single-layer frame

# The face side of cladding

Selecting the face side of cladding is essential for its long-term performance and visual appeal. Please note that the appropriate side may differ depending on the type of wood.

Use heartwood upside for Brolis thermo pine (see Fig. 1).

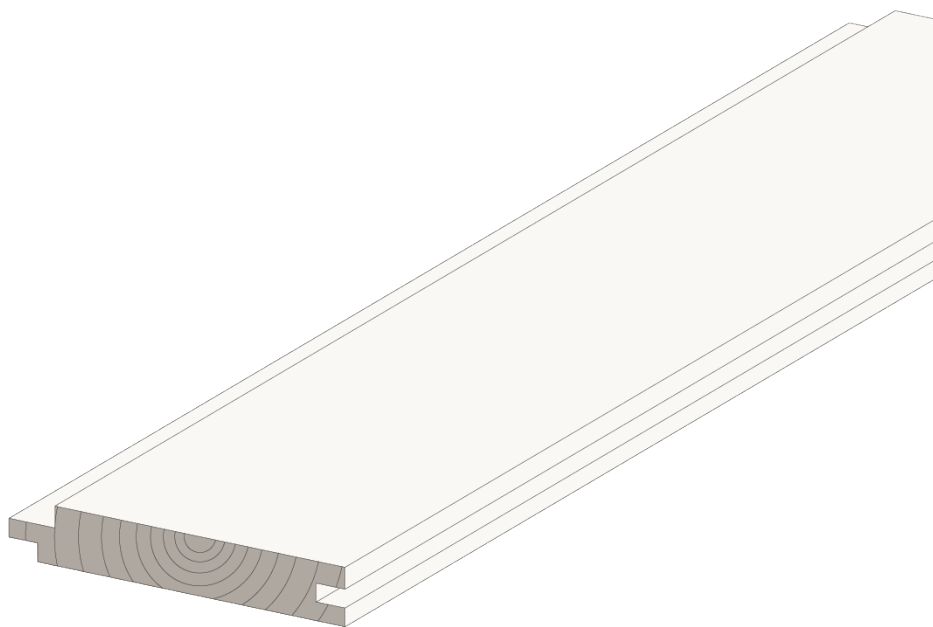
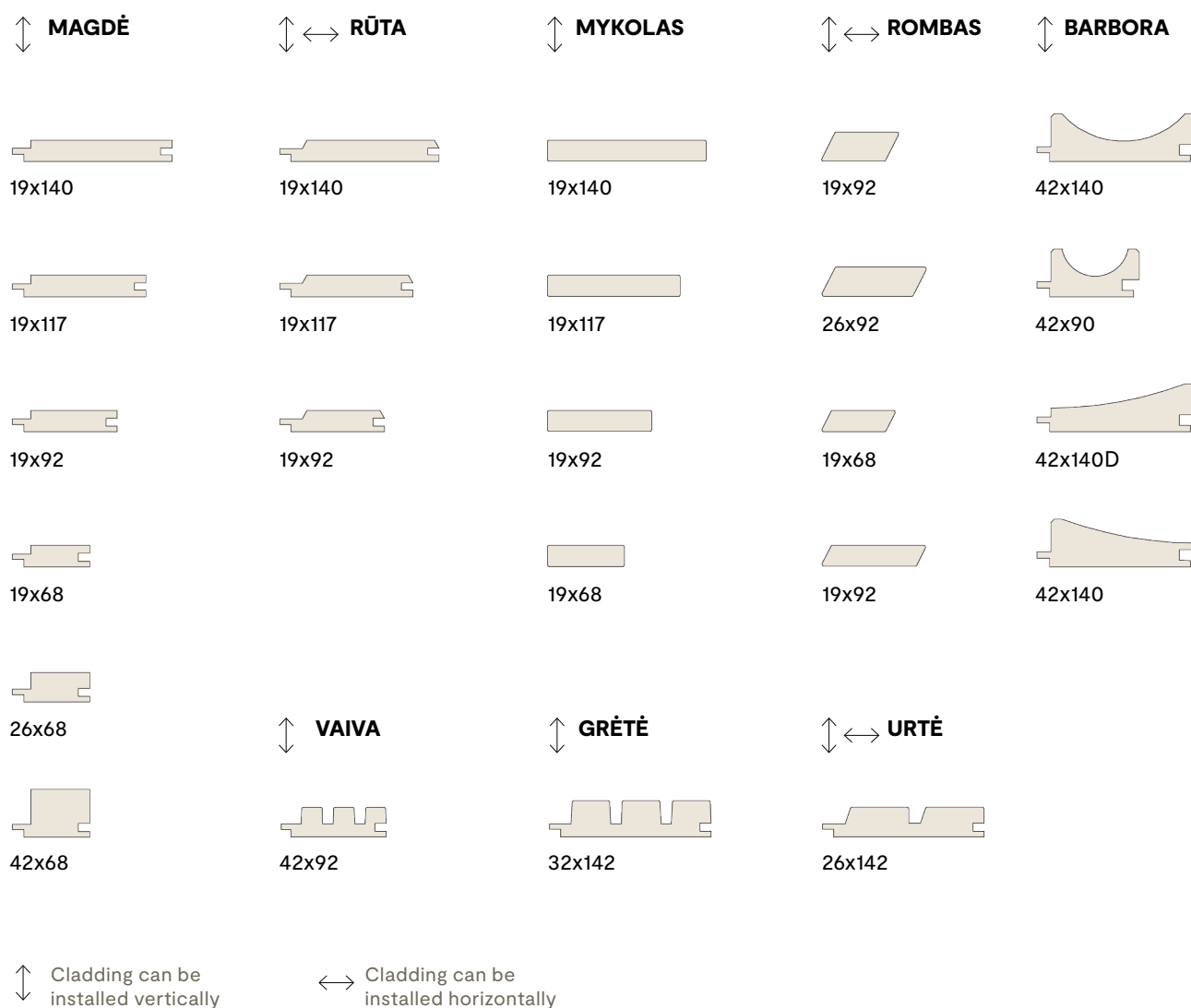

Fig. 1: Pine cladding upside (heartwood up)

## 03.2 Profiles and cladding orientation

# Profiles and cladding orientation



While cladding orientation is undoubtedly an important tool for architectural expression, it also has functional aspects influenced by environmental factors such as precipitation, prevailing winds, sunlight, and shading.

Vertical cladding is the optimal solution as its orientation aligns with the natural path of falling water, making the façade easier to maintain.

Although horizontal cladding retains more moisture — which can affect wood's durability over time — it is a more economical option, as it does not require a double-layer frame.

Diagonal cladding requires more experience, as it is more challenging to align with building openings and ensure neat connections. It is also harder to avoid critical points where moisture may accumulate. Furthermore, this installation method requires more materials for both the frame and the finish, making it more expensive.

## 03.3 Fasteners and fixing methods

# Basic fixing principles

All fixings intended for thermo timber must be made of stainless steel, category A2 or A4. If this recommendation is not followed, the metal will eventually oxidize, causing black streaks to appear at the fixing points.

Thermo cladding can be fixed using wood screws, self-drilling screws, nails or hidden fixings.

The head of the wood screw or nail must be flush with the cladding board (see Fig. 1). Therefore, choose screws with a tapered head for easier installation. If wood screws are driven in too deeply, water and dirt may accumulate in the resulting holes, causing the wood to darken in those areas. This can lead to staining or streaking.

The length of the wood screw or nail should be at least twice the thickness of the cladding board.

When fastening, maintain the minimum distances from the board edges shown below (see Fig. 2). If fastening

closer than 70 mm from the end of the cladding board is unavoidable, pre-drill a hole before inserting the screw. This will help prevent splitting.

Tvirtindami laikykitės žemiau parodytų minimalių atstumų nuo lentos briaunos (pav. 2). Jei kitaip neišeina, ir tenka tvirtinti arčiau nei 70 mm nuo dailylentės galo, prieš sukdami varžtą, išgręžkite skylę. Taip išvengsite skilimo.

One fixing point per frame batten is sufficient for narrow cladding boards up to 92 mm wide (without tongue and groove), or up to 117 mm wide (with tongue and groove). Wider boards require two fixing points.

We recommend fixing each cladding board to at least three horizontal or vertical frame battens.

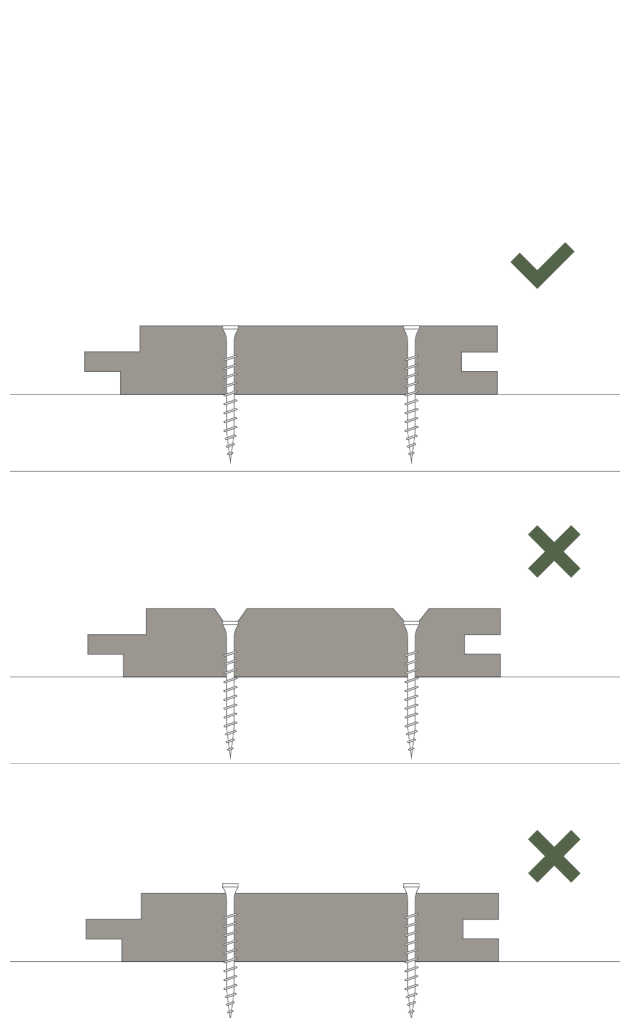

Fig. 1: The head of the wood screw or nail must be flush with the cladding board

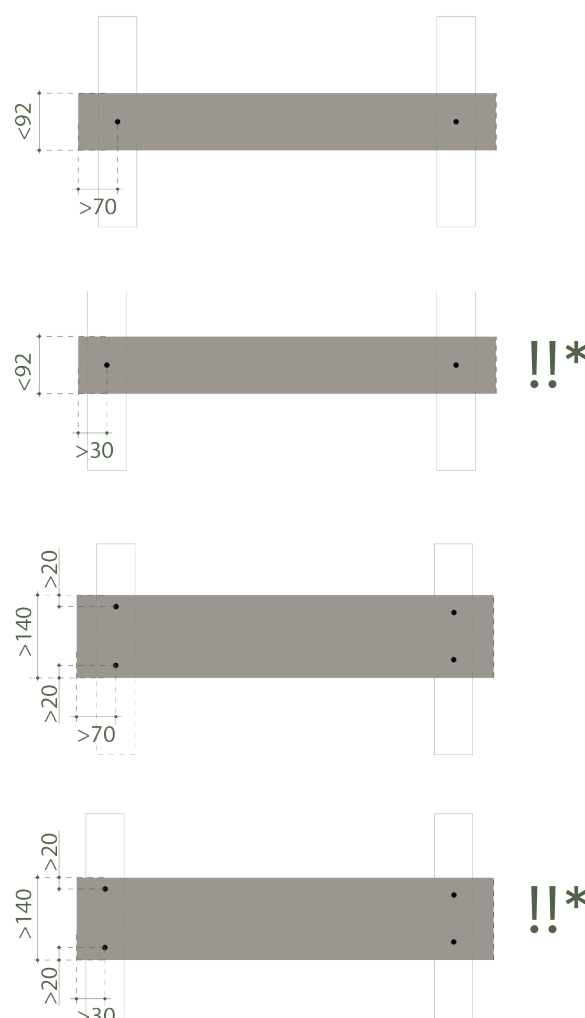

Fig. 2: Recommended fastening distances from board edges  
\* Pre-drilling of holes is required

# Installation of MAGDÉ and RŪTA profiles

Brolis thermo cladding profiles 'Magdé' and 'Rūta', regardless of width or thickness, can be fastened using wood screws, self-drilling screws, nails or hidden fixings.

The simplest and most reliable method is to fasten the cladding through the board using wood screws. For a less noticeable fixing, use headless nails.

For narrower cladding boards up to 117 mm wide, a single fixing point is enough (see Fig. 1). Wider boards require two fixing points on each horizontal or vertical batten (see Fig. 2).

Cladding boards with tongue and groove can be fixed using 5 mm high hidden fixings (see Fig. 3).

Narrower cladding boards up to 117 mm wide can also

be fixed using a nail gun to shoot headless nails at a 30° angle into the tongue (see Fig. 3). For boards wider than 117 mm, an additional fixing point through the board is required.

When installing cladding vertically with a single fixing point — using headless nails or hidden fixings — make sure to additionally secure cladding board ends and edge boards with two fixing points by driving an extra headless nail or wood screw through the board.

Note! All fixings intended for thermo timber must be made of A2 or A4 category stainless steel.

\*We recommend using nail guns only with a thermowood subframe — otherwise, dimensional movement of the subframe may result in an uneven facade.

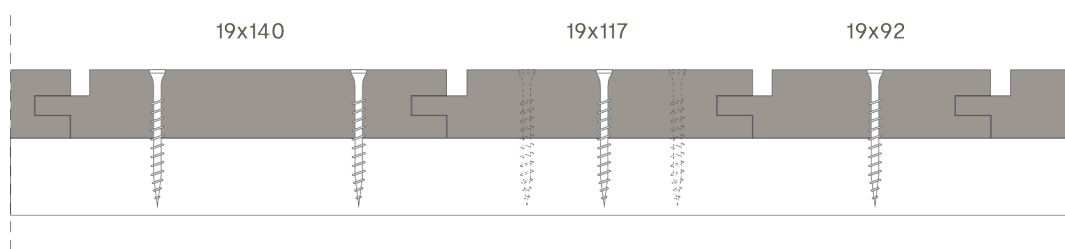

Fig. 1: Fastening through the boards of different widths

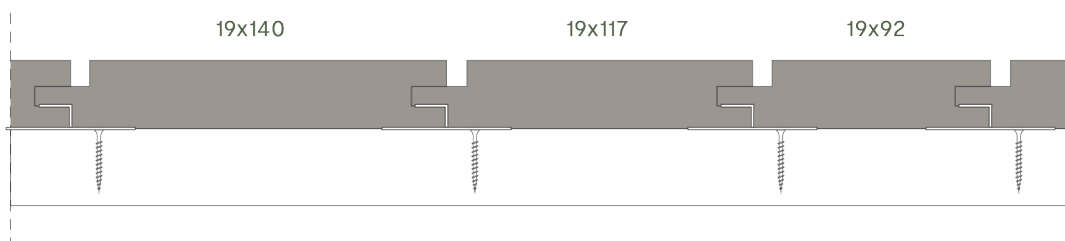

Fig. 2: Fastening of cladding boards using hidden fixings

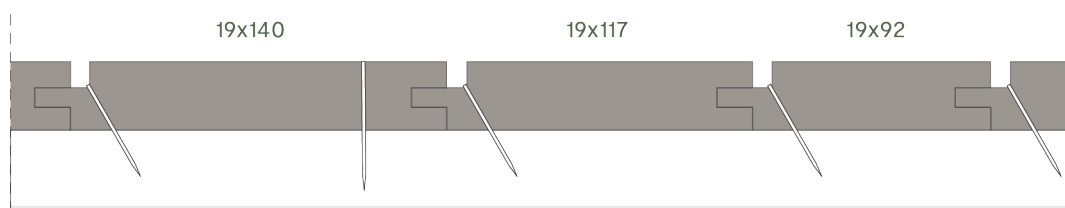

Fig. 3:\* Hidden fixing of cladding boards using headless nails for boards of different widths

# Installation of GRÊTÈ and VAIVA profiles

Brolis thermo cladding profiles 'Grêtè' and 'Vaiva' can be fastened using wood screws, self-drilling screws, nails or hidden fixings.

The simplest and most reliable method is to fasten the cladding through the board into the grooved parts of the profile using wood screws (see Fig. 1; 2). For a less noticeable fixing, use headless nails (See Fig. 3; 4).

A single fixing point is enough for narrower 'Vaiva' cladding boards. Wider 'Grêtè' boards require two fixing points on each horizontal batten. When using headless nails, the second nail can be driven at a 30° angle into the tongue to achieve an almost invisible finish.

Cladding boards with tongue and groove can be fixed using 5 mm high hidden fixings (see Fig. 5; 6).

When installing cladding vertically with a single fixing point — using headless nails or hidden fixings — make sure to additionally secure cladding board ends and edge boards with two fixing points by driving an extra headless nail or wood screw through the board.

Note! All fixings intended for thermo timber must be made of A2 or A4 category stainless steel.

\* We recommend using nail guns only with a thermowood subframe — otherwise, dimensional movement of the subframe may result in an uneven facade.

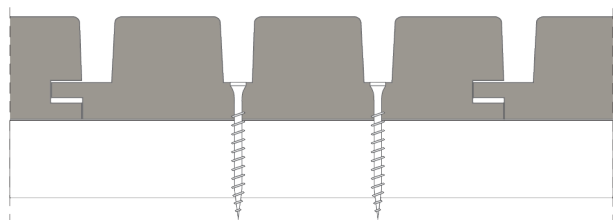

Fig. 1: Fastening GRÊTÈ cladding through the board

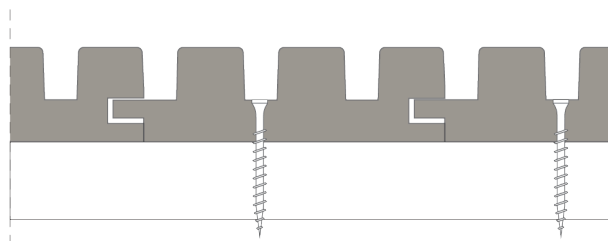

Fig. 2: Fastening VAIVA cladding through the board

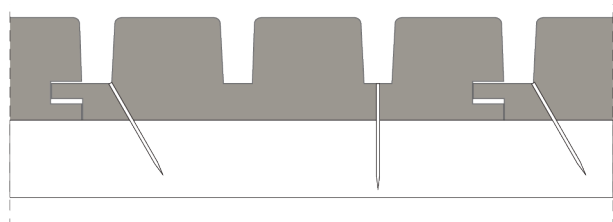

Fig. 3:\* Fastening GRÊTÈ cladding boards using headless nails

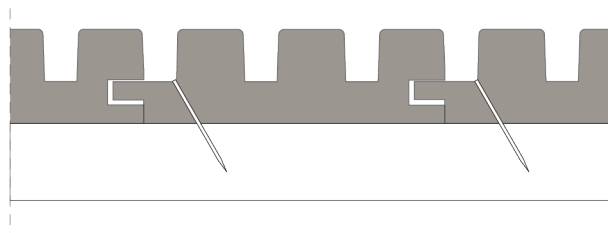

Fig. 4:\* Fastening VAIVA cladding boards using headless nails

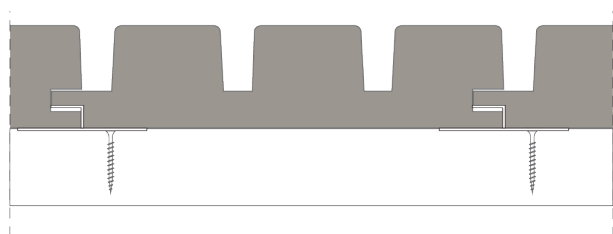

Fig. 5: Fastening of GRÊTÈ cladding boards using hidden fixings

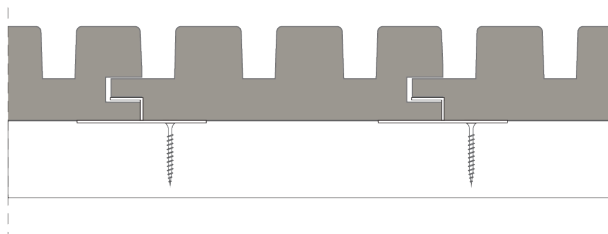

Fig. 6: Fastening of VAIVA cladding boards using hidden fixings

# Installation of URTÉ profile

Brolis thermo cladding profile 'Urté' can be fastened using wood screws, self-drilling screws, nails or hidden fixings.

The simplest and most reliable method is to fasten the cladding boards together through the board into the grooved parts of the profile using wood screws (see Fig. 1). For a less noticeable fixing, use headless nails (See Fig. 2).

Secure the boards with two fixings on each horizontal or vertical batten. The second fixing should be screwed into the tongue of the cladding board at a 30° angle.

'Urté' cladding boards can be fixed using 5 mm high hidden fixings (see Fig. 3).

When installing cladding vertically with hidden fixings make sure to additionally secure cladding board ends and edge boards with two fixing points by driving an extra headless nail or wood screw through the board.

Note! All fixings intended for thermo timber must be made of A2 or A4 category stainless steel.

\* We recommend using nail guns only with a thermowood subframe – otherwise, dimensional movement of the subframe may result in an uneven facade.

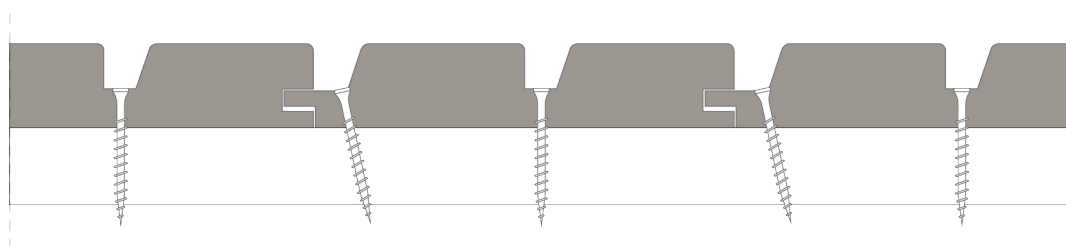

Fig. 1: Fastening URTÉ cladding through the board

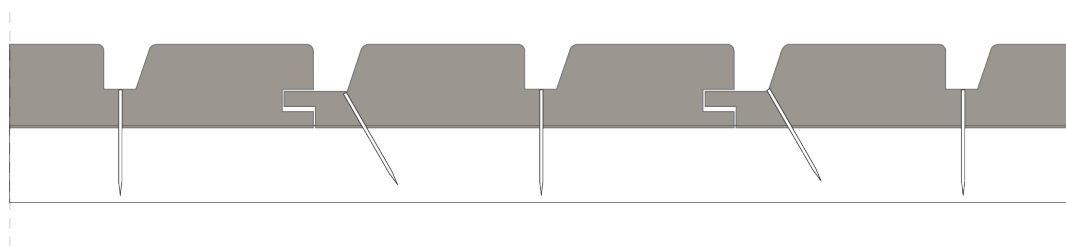

Fig. 2:\* Fastening URTÉ cladding boards using headless nails

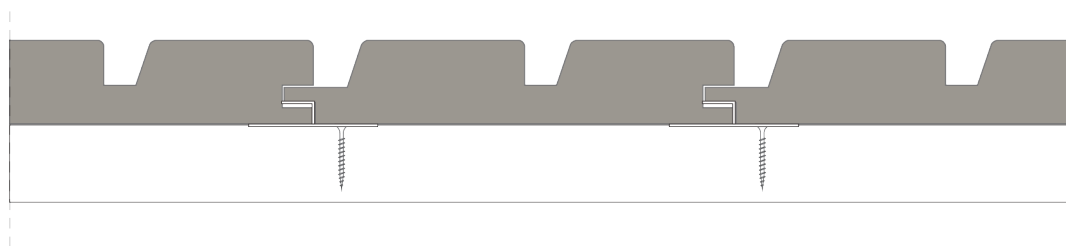

Fig. 3: Fastening of URTÉ cladding boards using hidden fixings

# Installation of non-grooved cladding

Non-grooved Brolis thermo cladding profiles ‚Mykolas‘ and ‚Rombas‘ can be fixed using wood screws, self-drilling screws or nails.

The simplest and most reliable method is to fasten the cladding boards together through the board. For a less noticeable fixing, use headless nails.

When using wood screws, a single fixing point is enough for cladding boards up to 117 mm wide (see Fig. 2; 5). Wider boards require two fixing points on each frame batten. When using headless nails, two fixing points are needed, regardless of board width (see Fig. 1; 4).

Furthermore, non-grooved cladding boards can be installed in 600-2000 mm long segments by fixing them from the back side. These pre-assembled cladding segments are mounted onto the façade structure, instead of installing individual boards. Although this method requires more precision and preparation, it offers a clean look with hidden fixings (see Fig. 3)

Note! All fixings intended for thermo timber must be made of A2 or A4 category stainless steel.

\* We recommend using nail guns only with a thermowood subframe – otherwise, dimensional movement of the subframe may result in an uneven facade.

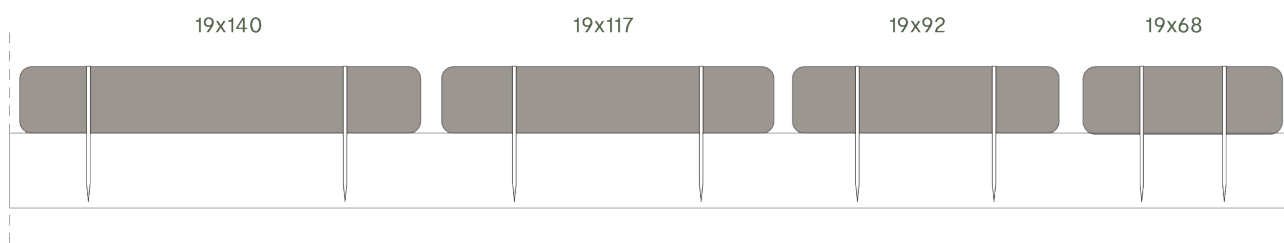

Fig. 1: Fastening using headless nails

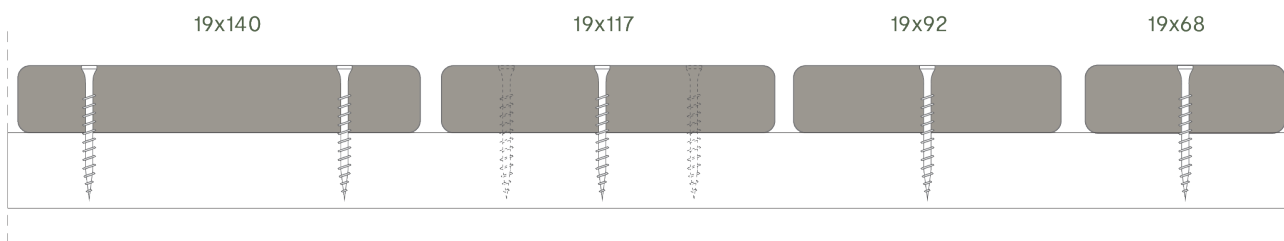

Fig. 2: Fastening through the board using wood screws

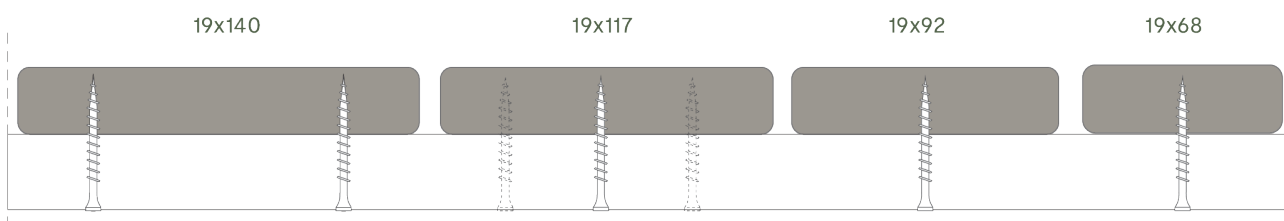

Fig. 3: Fastening when assembling cladding segments

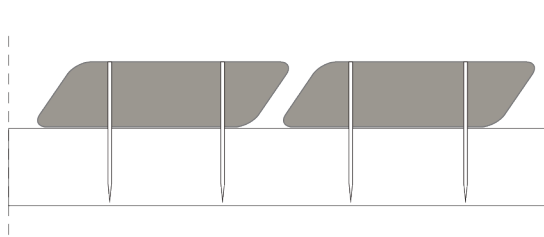
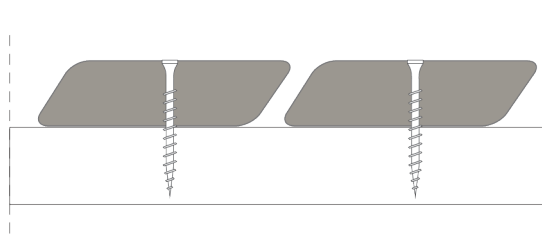

Fig. 4: Fastening using headless nails



Pav. 5: Fastening using wood screws

# Installation of battens

Brolis thermo battens can be fastened in several ways. The frame should be at least 42 mm thick for batten installation.

Fasten battens through the board (see Fig. 1). For battens exceeding 42x68 mm in size, we recommend pre-drilling a hole and countersinking the screw, ensuring the distance from the screw head to the frame is at least 68 mm.

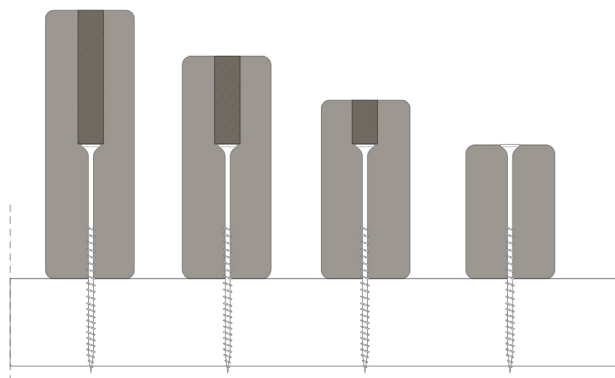

Fig. 1: Fastening battens through the board

Battens can be installed in 600–2000 mm long segments by fixing them from the back side. These pre-assembled batten segments are mounted onto the façade structure, instead of installing individual battens. Although this method requires more precision and preparation, it offers a clean look with hidden fixings (see Fig. 2)

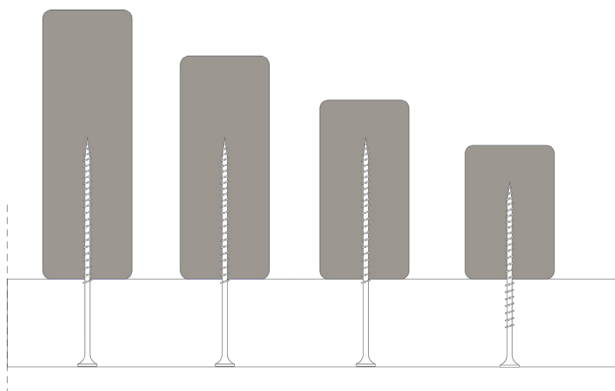

Fig. 2: Fastening when assembling batten segments

Battens can also be fastened to the frame by driving screws at an angle through the side edges. For taller battens (42x92/42x117/42x140), the screw angle should be up to 15°, and up to 30° for shorter battens (42x68). To ensure the wood screw head is hidden within the batten, it is recommended to pre-drill a hole (see Fig. 3).

**Note!** All fixings intended for thermo timber must be made of A2 or A4 category stainless steel.

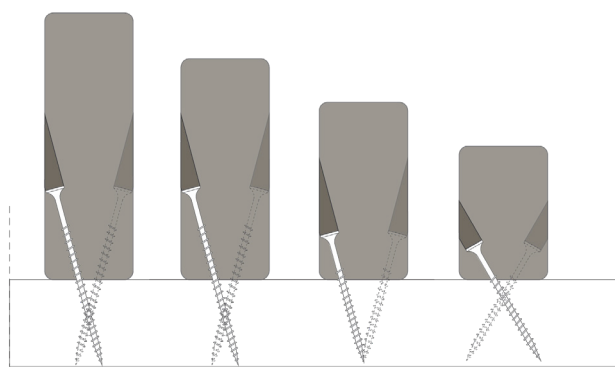
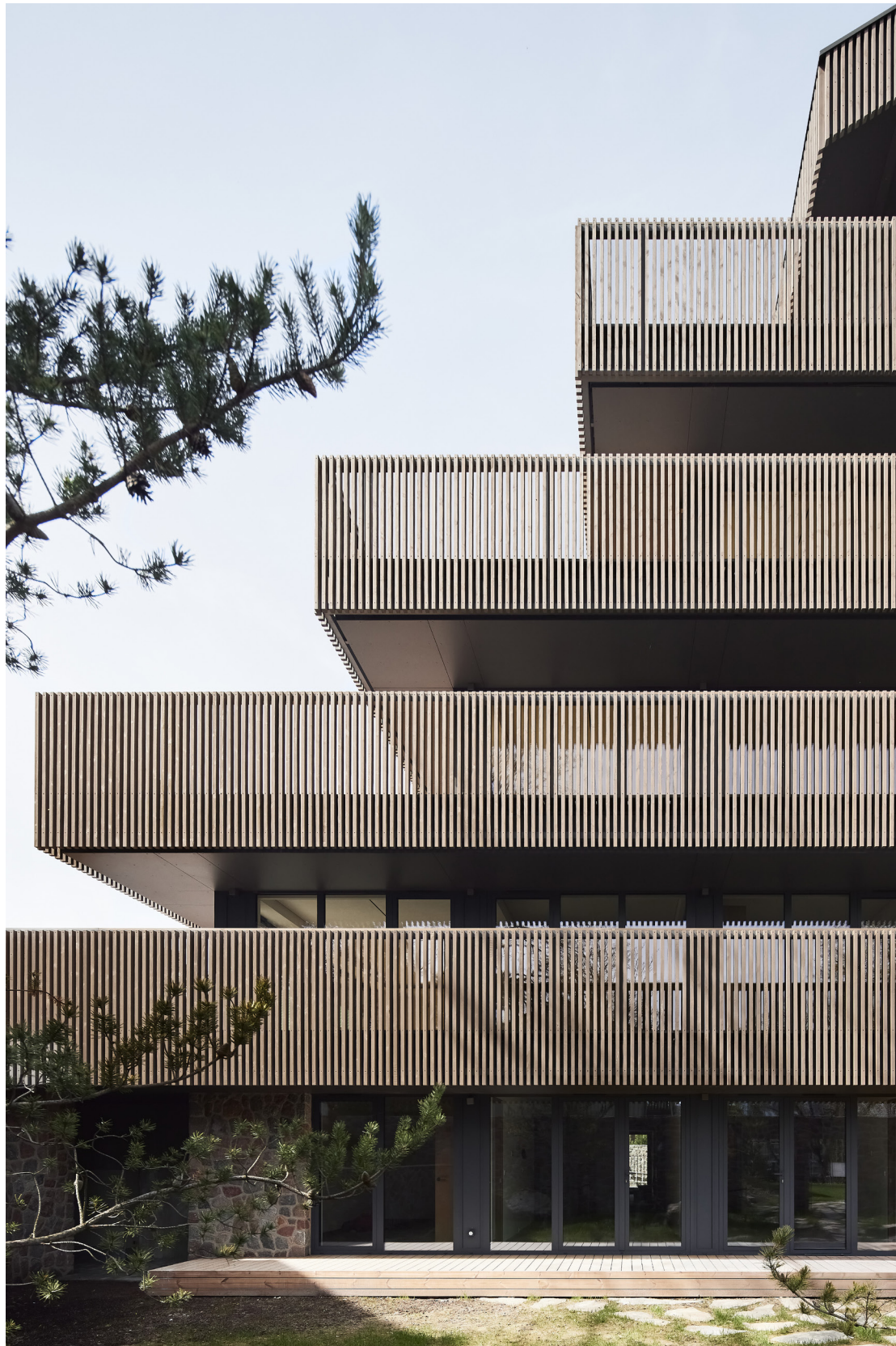

Fig. 3: Fastening battens at an angle



Pilkopė // Juodkrantė, Lithuania, 2023 // Profiles: Mykolas 26x117, Batten 42x68, Urtė 26x142  
// Coating: Tikkurila Wood Stain 5147, textured // Architects: Jurgis Algimantas Zaviša, 1978 //  
Reconstruction authors: UAB 'Laimos ir Ginto projektai', 2023 // Norbert Tukaj 2025

04

# Architectural design solutions

## 04.1

### For vertical cladding

This section focuses on specific architectural solutions that are designed to save your time by eliminating the need to reinvent the wheel. You will find a variety of functional and aesthetic options to help you bring impressive projects to life.



12 Bičiulių kvartalas 2023 // Profiles: Mykolas 19x92, brushed // Coating: 5089 // Architects: Dovydas Čipkus (MB 'Mes Architektai') // Photos: Gabrielius Lenksas



# Board joining options

General installation instructions described in the previous sections also apply to vertical cladding. Remember to install double horizontal battens at board joints to provide proper support for cladding ends (see Fig. 1), and cut the board ends at an angle to prevent water accumulation (see Fig. 2).

Bellow, we suggest several board joining options designed to maximize material outcome, reduce costs, and em-

phasize the timeless character of wooden architecture.

The simplest way to join cladding boards is by arranging the joints in a checkerboard pattern across the façade (see Fig. 3). This type of jointing is the least noticeable. If the length of the board allows, joints can be made in every other row (see Fig. 4).

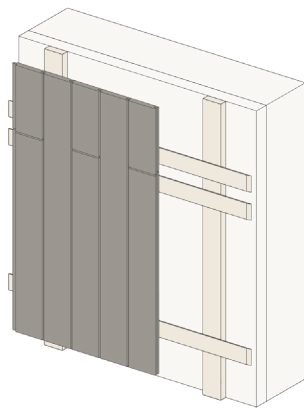

Fig. 1: Double horizontal batten at cladding board joints

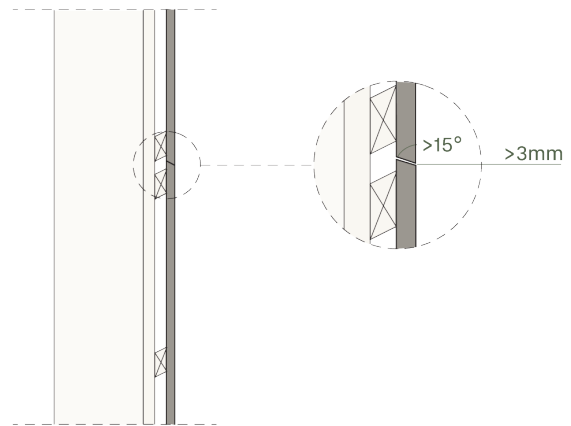

Fig. 2: Board ends cut at an angle to prevent water accumulation

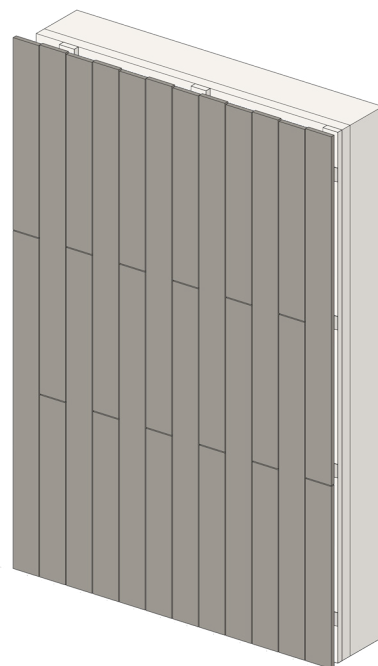

Fig. 3: Cladding board joints arranged in a checkerboard pattern

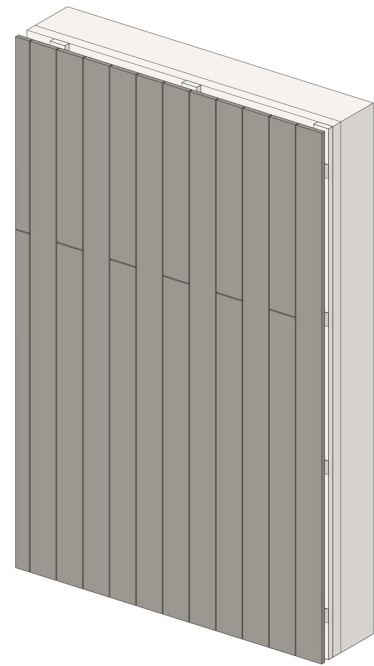

Fig. 4: Cladding board joints in every other row

# Board joining options

Cladding joints can be aligned in a straight line. To achieve visual balance, it is recommended to align the joints with the compositional line of the façade – for example, the top or bottom of a window opening (see Fig. 5).

The continuous joint line can be intentionally emphasized by using cladding boards of different widths (see Fig. 6).

Furthermore, additional horizontal elements can be introduced – both the 28x42 mm ‘Pusrombis’ profile (see Fig. 7; 8) and folded metal sheets are excellent options for this purpose.

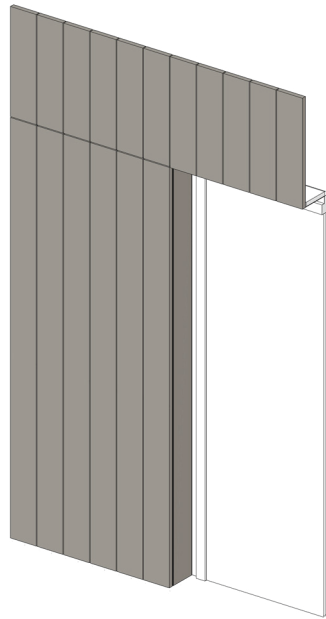

Fig. 5: Cladding joints aligned with the top edge of the window opening

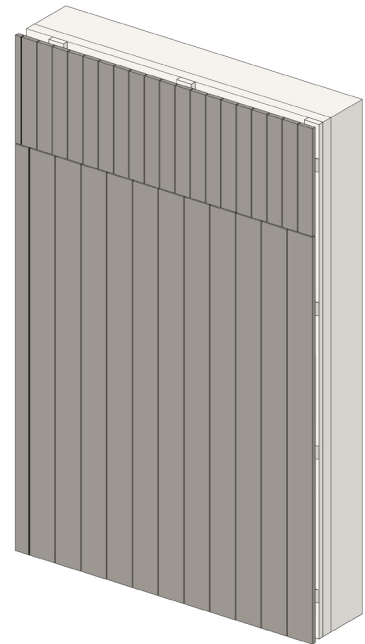

Fig. 6: Cladding joints using boards of different widths

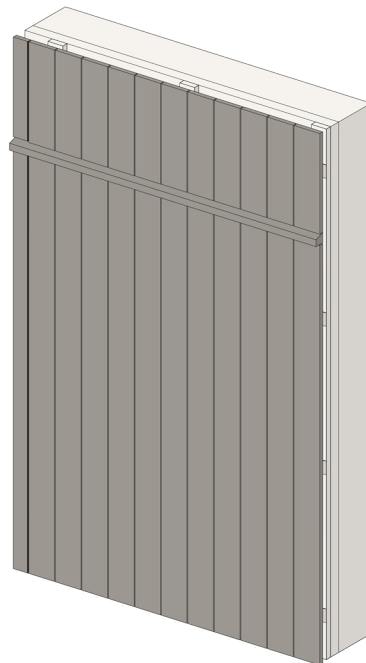

Fig. 7: Cladding joints with a horizontal 28x42 PUSROMBIS profile element

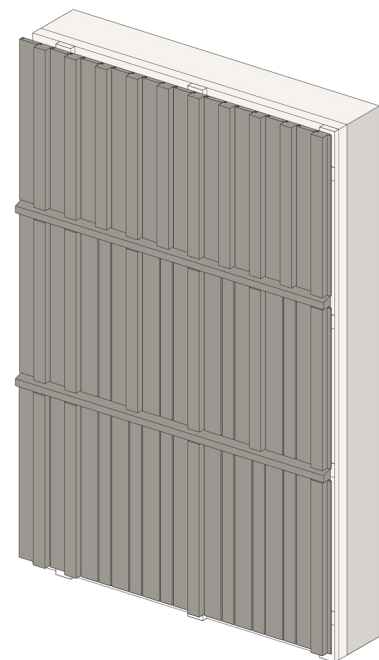
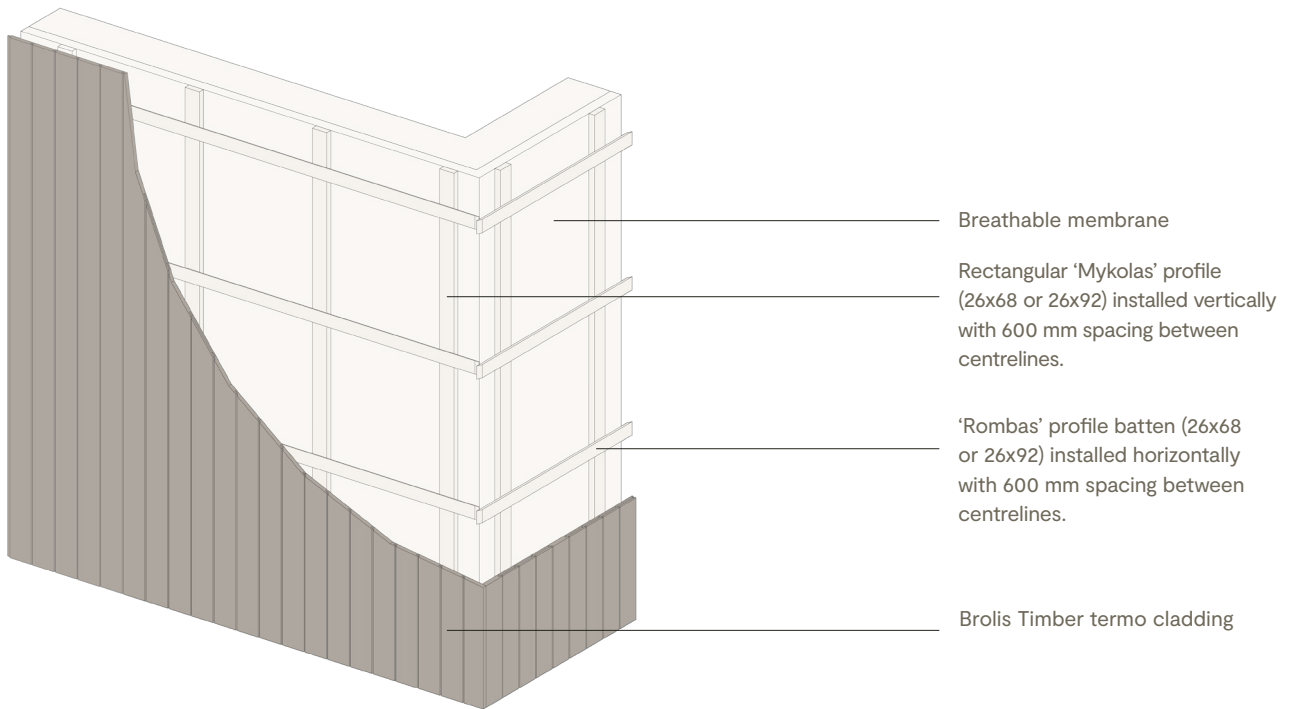
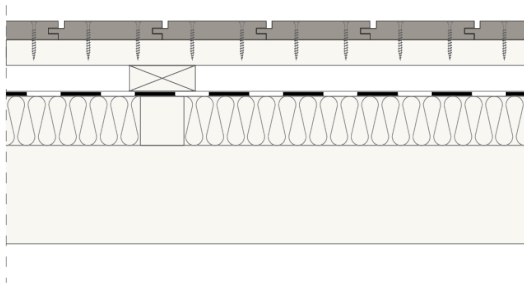

Fig. 8: Cladding joints with multiple horizontal 28x42 PUSROMBIS profile elements

# Grooved cladding details



Vertical grooved cladding on a double-layer wooden frame. All Brolis Timber cladding profiles can be mixed and matched to create a wide variety of unique patterns.



Thermo cladding MAGDÉ (19x117), fastened with wood screws onto a double-layer wooden frame

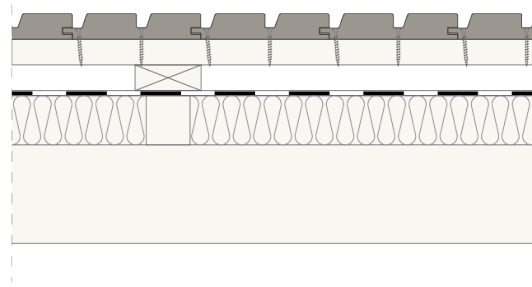

Thermo cladding URTÉ (26x142), fastened with wood screws onto a double-layer wooden frame

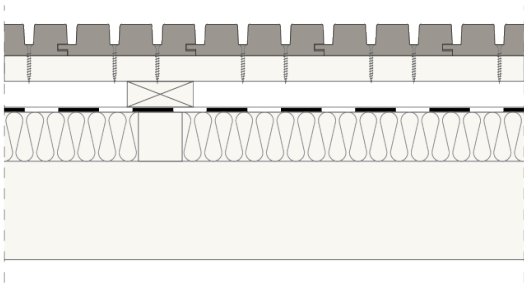

Thermo cladding GRÉTÉ (32x140), fastened with wood screws onto a double-layer wooden frame

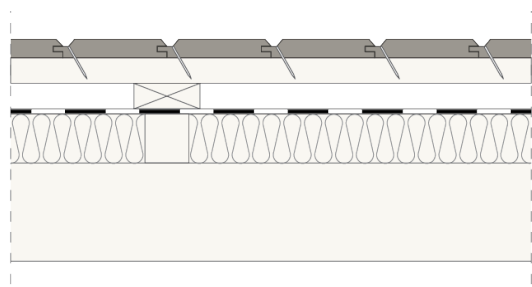

Thermo cladding RŪTA (19x117), fastened with headless nails onto a double-layer wooden frame

# Corner finishing with MAGDĚ and RŪTA profiles

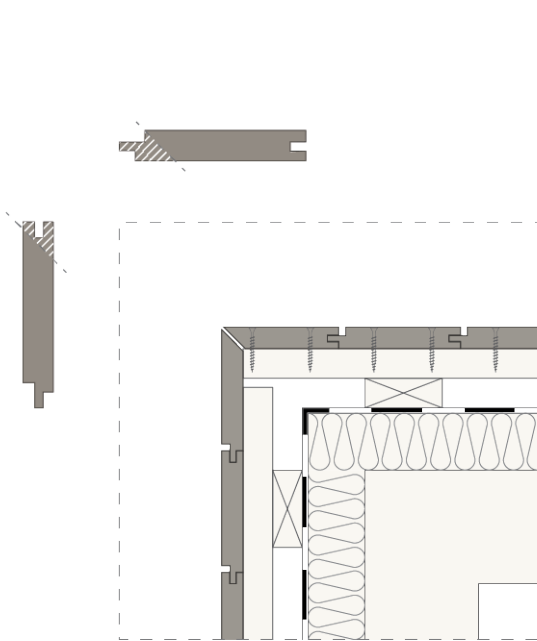

Fig. 1: External corner finishing by cutting the board edges at a 45° angle

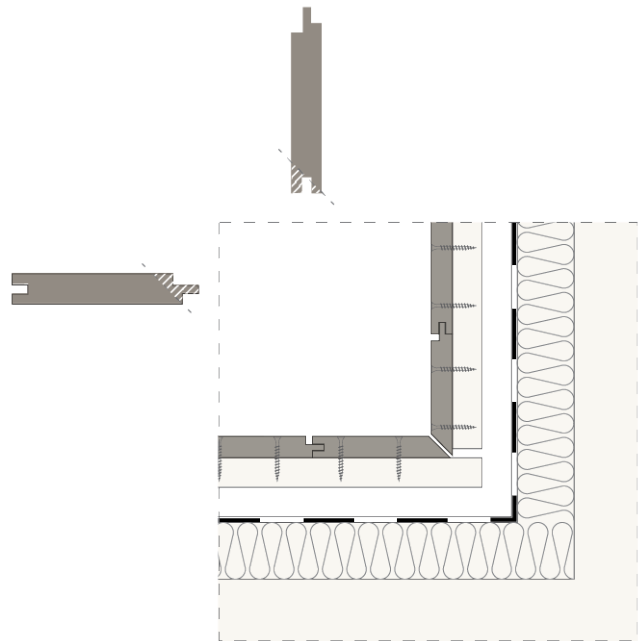

Fig. 2: Internal corner finishing by cutting the board edges at a 45° angle

In vertical cladding, both external and internal corners of grooved cladding boards can be finished in two ways:

- by cutting the board edges at a 45° angle (see Fig. 1; 2)
- by cutting off the groove edge of one of the boards (see Fig. 3; 4)

Make sure to leave a gap of at least 3 mm to for ventilation and wood movement when joining the boards.

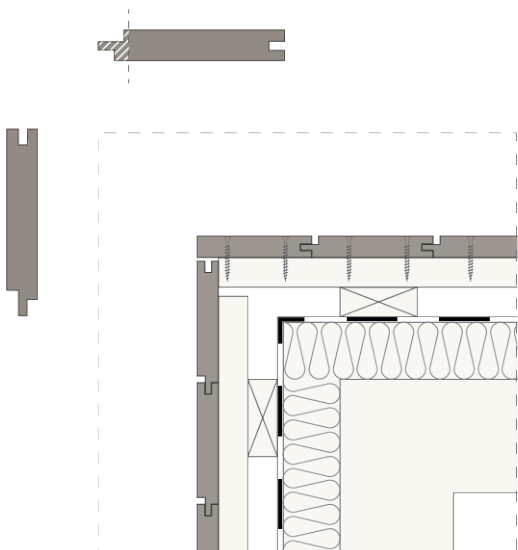

Fig. 3: External corner finishing by cutting off the groove edge of one of the boards

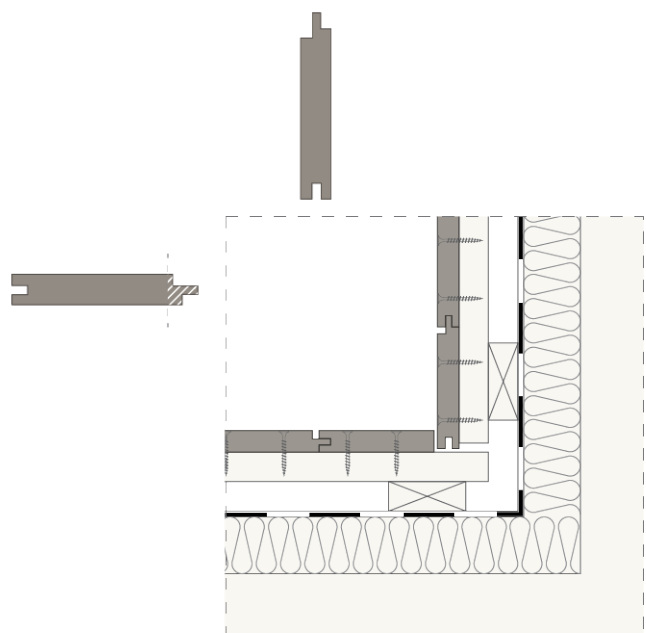

Fig. 4: Internal corner finishing by cutting off the groove edge of one of the boards

# Corner finishing with GRÈTÈ and VAIVA profiles

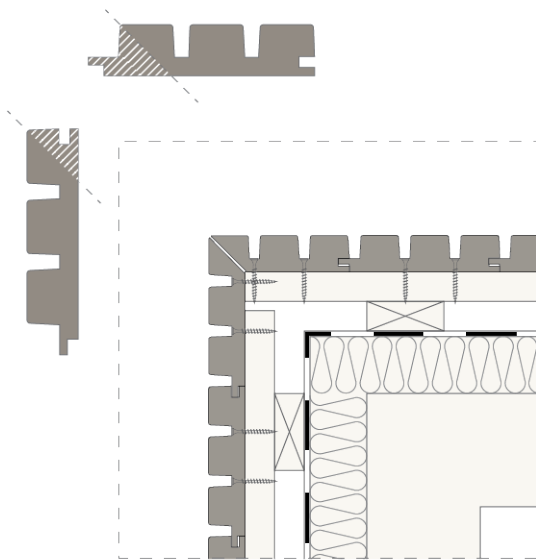

Fig. 1: External corner finishing by cutting the board edges at a 45° angle

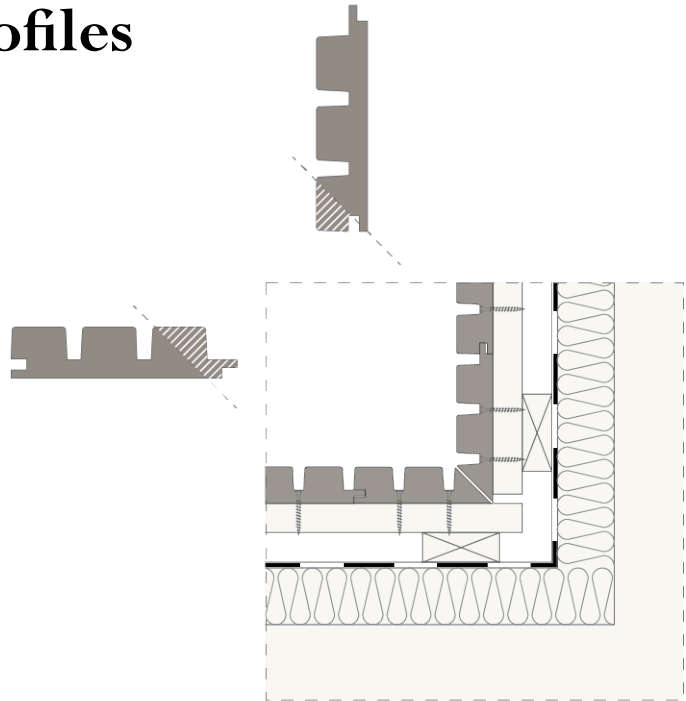

Fig. 2: Internal corner finishing by cutting the board edges at a 45° angle

In vertical cladding, both external and internal corners of grooved cladding boards can be finished in two ways:

- by cutting the board edges at a 45° angle (see Fig. 1; 2)
- by cutting off both the tongue and groove edges of the two connecting boards (see Fig. 3; 4)

Make sure to leave a gap of at least 3 mm to for ventilation and wood movement when joining the boards.

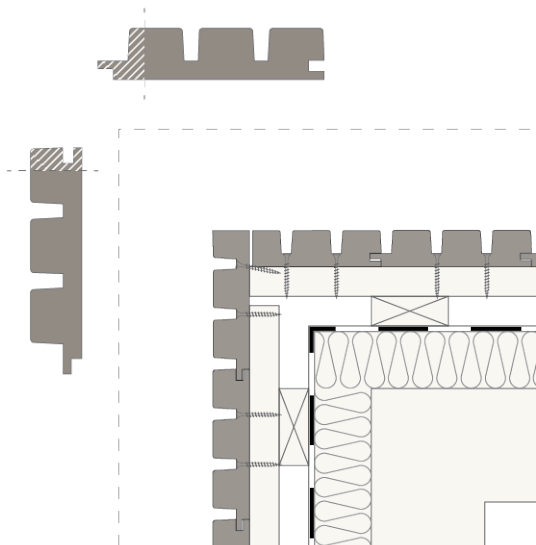

Fig. 3: External corner finishing by cutting off both the tongue and groove edges of the two connecting boards

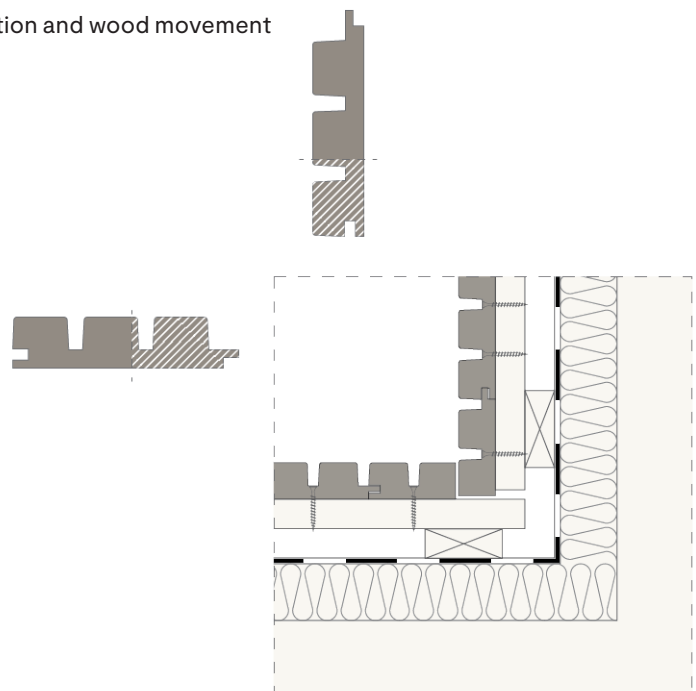

Fig. 4: Internal corner finishing by cutting off both the tongue and groove edges of the two connecting boards

# Corner finishing with URTÉ profile

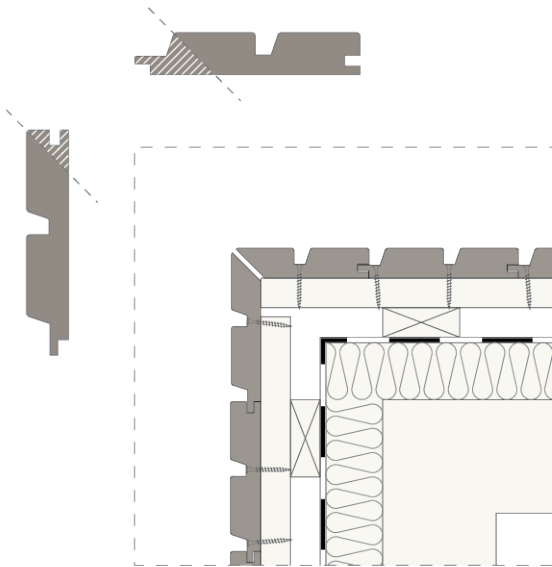

Fig. 1: External corner finishing by cutting the board edges at a 45° angle

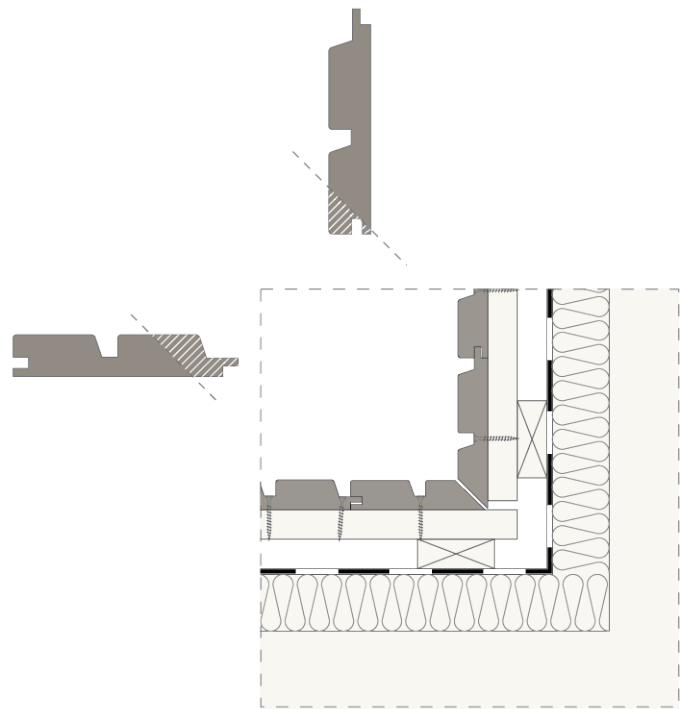

Fig. 2: Internal corner finishing by cutting the board edges at a 45° angle

In vertical cladding, both external and internal corners of grooved cladding boards can be finished in two ways:

- by cutting the board edges at a 45° angle (see Fig. 1; 2)
- by cutting off both the tongue and groove edges of the two connecting boards (see Fig. 3; 4)

Make sure to leave a gap of at least 3 mm to for ventilation and wood movement when joining the boards.

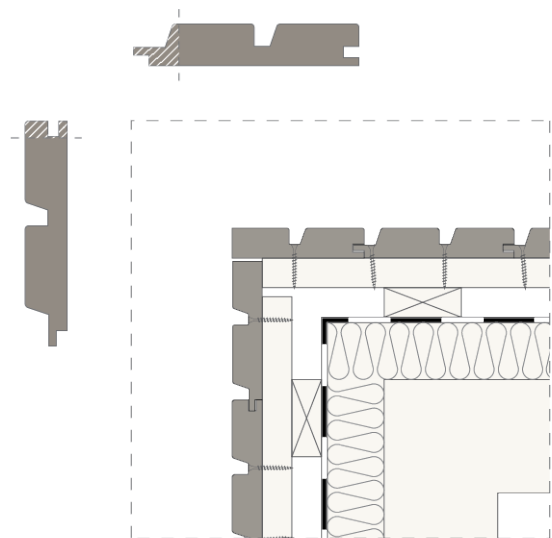

Fig. 3: External corner finishing by cutting off both the tongue and groove edges of the two connecting boards

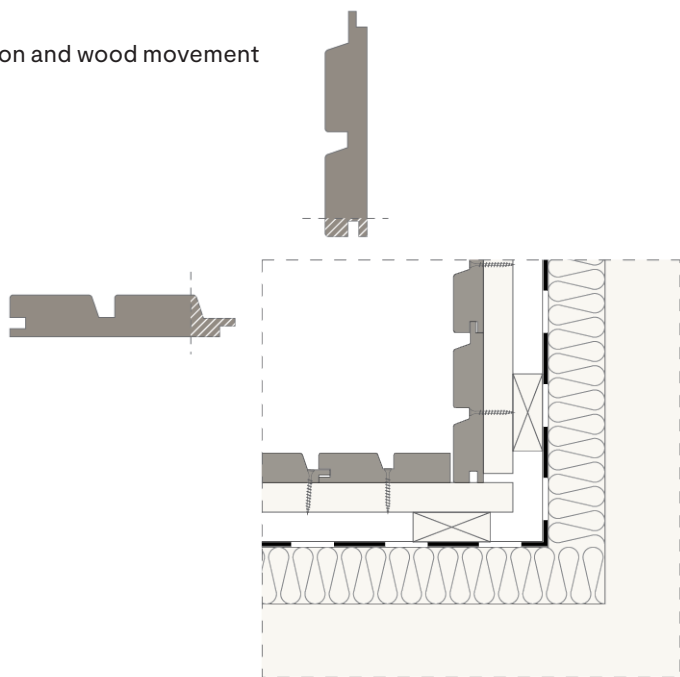
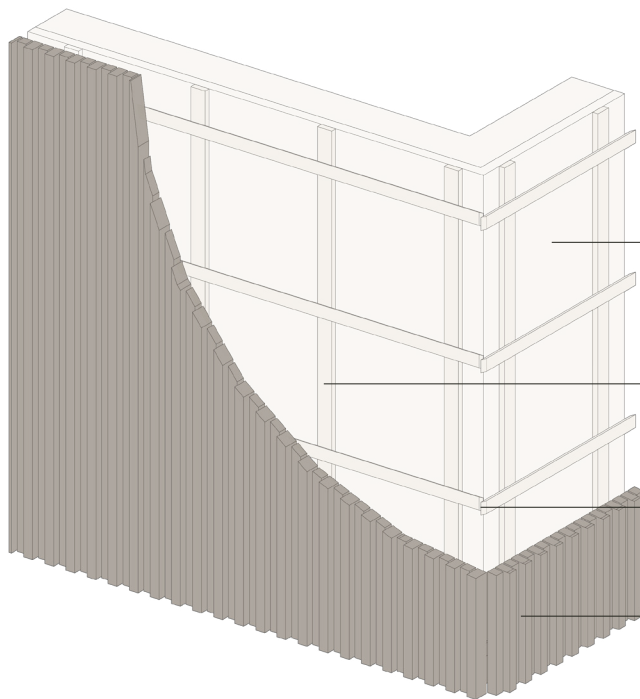

Fig. 4: Internal corner finishing by cutting off both the tongue and groove edges of the two connecting boards



Private residential building // Kaunas, 2023 // Profiles: Mykolas 26x117 and Grète 32x142 // Coating: TK WS 5147, not textured // Architects: Nebrau Architecture // Photo: Norbert Tukaj

# Non-grooved cladding details



Breathable membrane. If cladding boards are installed with gaps that allow sunlight to pass through, the breathable membrane must be UV-resistant.

Rectangular 'Mykolas' profile (26x68 or 26x92 mm), installed vertically with 600 mm spacing between centrelines.

'Rombas' profile batten (26x68 or 26x92), installed horizontally with 600 mm spacing between centrelines.

Brolis Timber termo battens

Vertical non-grooved cladding or battens on a double-layer wooden frame. All Brolis Timber cladding profiles can be mixed and matched to create a wide variety of unique patterns. For fastening battens taller than 68 mm, choose horizontal battens with a thickness of 42 mm.

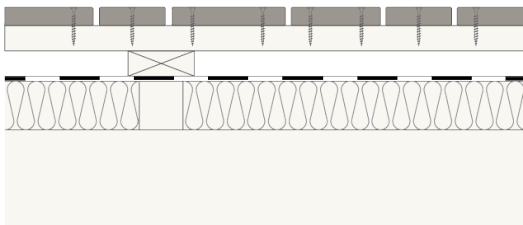

Thermo cladding 'Mykolas' (various widths), fastened with wood screws onto a double-layer wooden frame

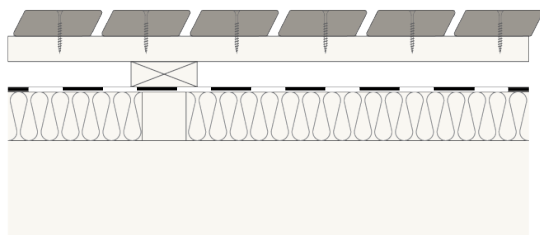

Thermo cladding 'Rombas' (26x29), fastened with wood screws onto a double-layer wooden frame

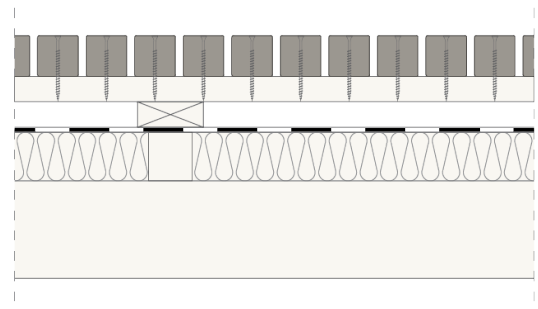

Thermo battens (42x42), fastened with wood screws onto a double-layer wooden frame

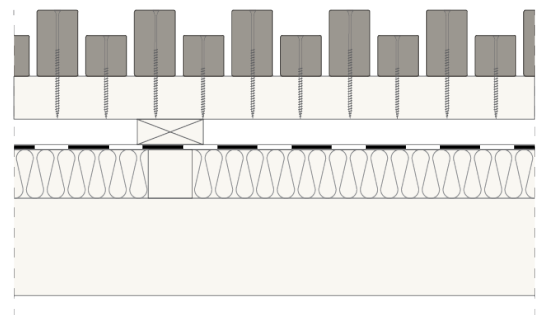

Thermo battens (42x42 and 42x68), fastened with wood screws onto a double-layer wooden frame

# Corner finishing with MYKOLAS profile and battens

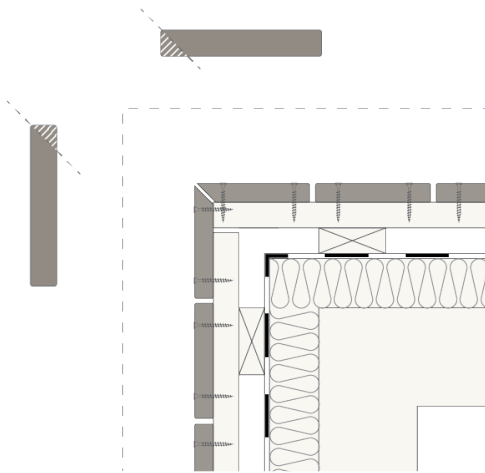

Fig. 1

In vertical cladding, both external and internal corners of grooved cladding boards can be finished in two ways:

- by overlapping the cladding boards (see Fig. 2; 3)
- by cutting the board edges at a 45° angle (see Fig. 1)

Make sure to leave a gap of at least 3 mm for ventilation and wood movement when joining the boards.

When forming corners using battens, no cutting is required (see Fig. 4; 5).

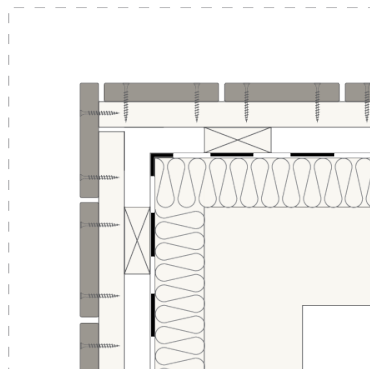

Fig. 2

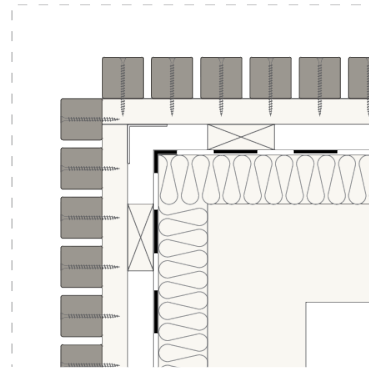

Fig. 4

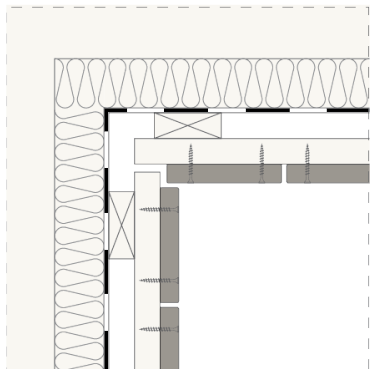

Fig. 3

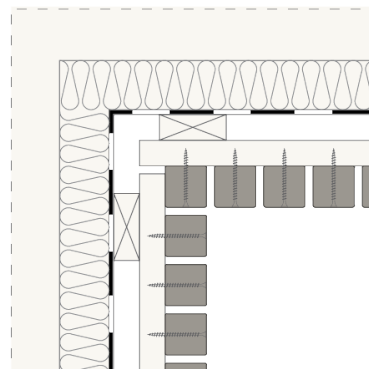

Fig. 5

# Opening edges design

When installing vertical cladding, cut the board ends at an angle of at least 15° near openings to prevent moisture accumulation (see Fig. 1).

The trim board covering opening edges can be hidden behind the façade cladding boards (see Fig. 2). When using grooved cladding, cut off the tongue edge – this does not affect the durability of the cladding, as termo timber is modified throughout its full thickness.

Alternatively, the trim board covering the window reveal can be extended slightly beyond the facade, creating a clean, graphic frame for the opening (see Fig. 3)

To achieve neat corners around openings, cut the edges of the cladding boards at a 45° angle along their length (see Fig. 4). Make sure to leave a gap of at least 3 mm.

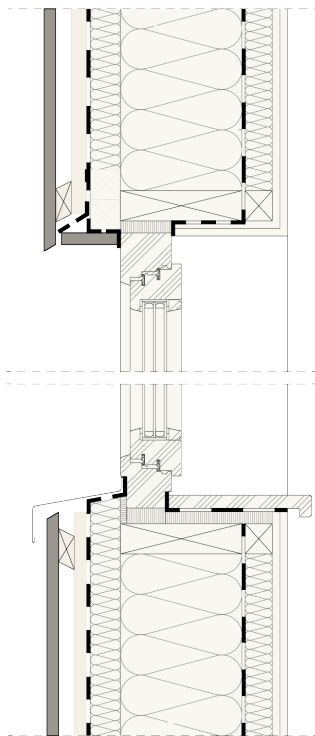

Fig. 1

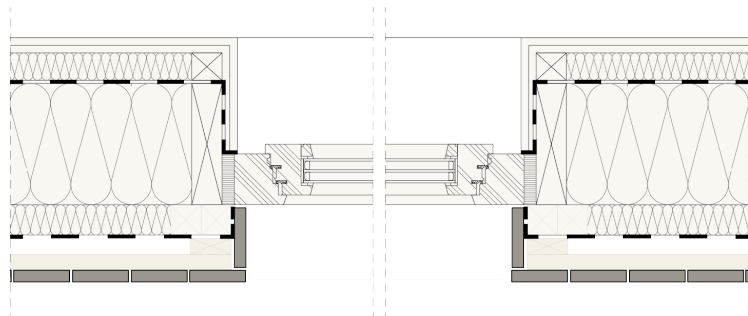

Fig. 2

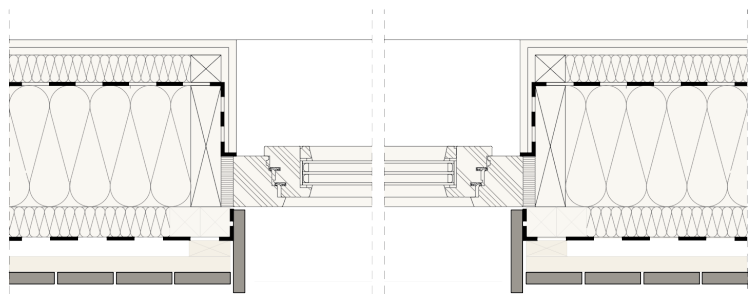

Fig. 3

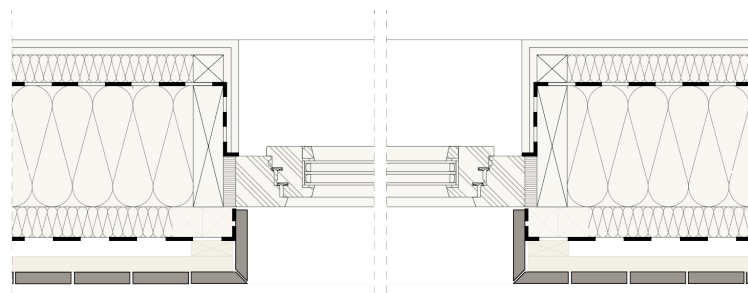
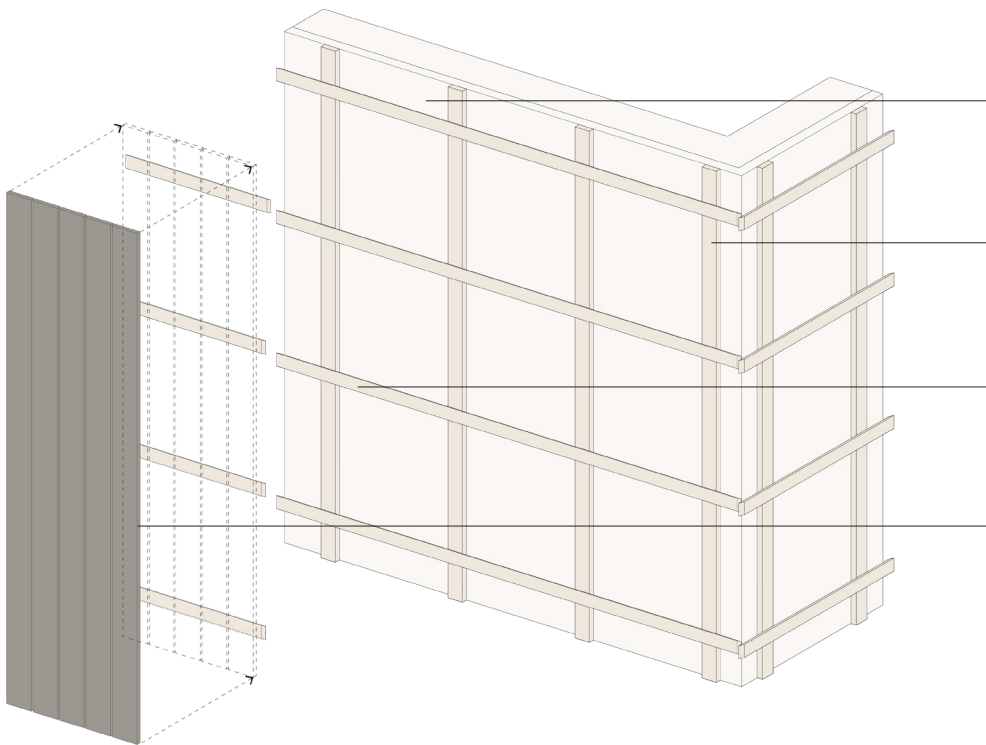

Fig. 4



Namiele group 2024 // Profiles: Magdè 19x92, Magdè19x68 // Photo: Vaidotas Darulis

# Cladding segment installation



1 Step

Breathable membrane. If cladding boards are installed with gaps that allow sunlight [ÜP12.1] to pass through, the breathable membrane must be UV-resistant

Rectangular 'Mykolas' profile (26x68 or 26x92) installed [ÜP13.1] vertically with 600 mm spacing between centrelines

'Rombas' profile batten (26x68 or 26x92) installed horizontally with 600 mm spacing between centrelines

Prie-assembled segment:

- 'Rombas' profile batten (26x68 or 26x92), installed horizontally with 600 mm spacing between centrelines.

- Cladding made from Brolis termo battens

Cladding segment is assembled separately and then mounted onto the structural frame.

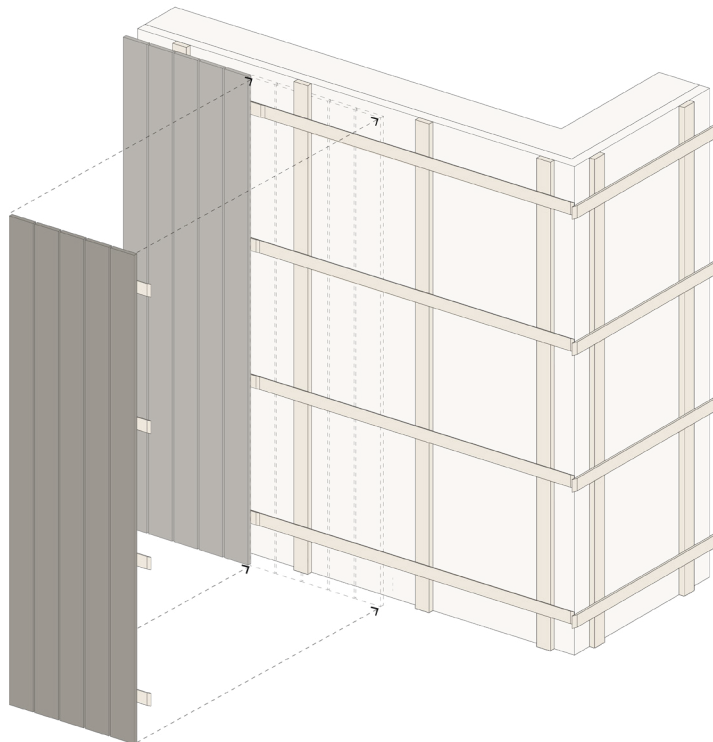

2 Step

# Cladding segment installation

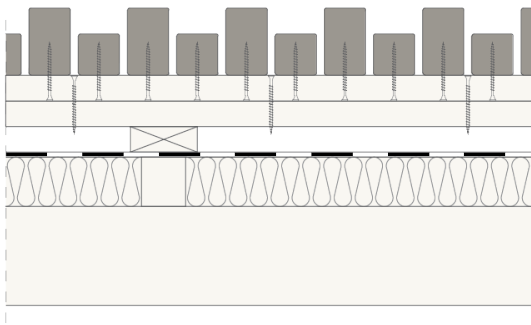

Fig. 1: Installation onto double battens

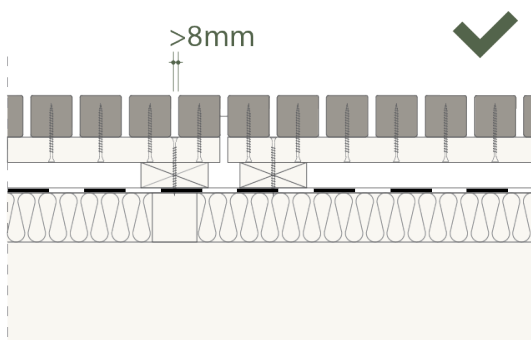

Fig. 2: Correct installation onto vertical battens

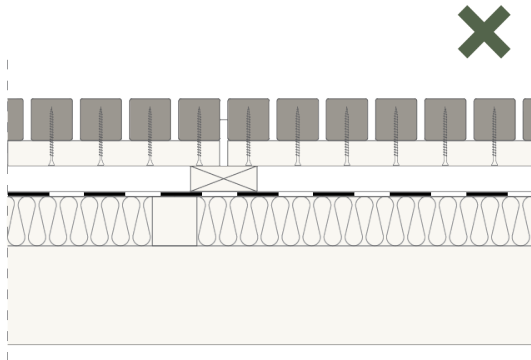

Fig. 3: Incorrect installation onto vertical battens

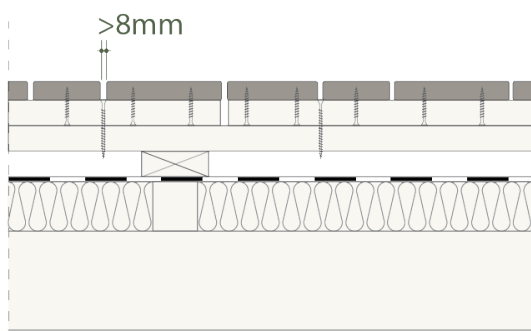

Fig. 4: Gap between cladding boards  $\geq 8$  mm

To avoid visible fixing, battens or non-grooved cladding boards can be installed onto the structural frame as pre-assembled segments. The segments, 600–2000 mm wide, should be prepared in advance – either on site or in the factory.

Cladding segments can be fastened onto double horizontal battens (see Fig. 1) or directly onto vertical frame battens, attached to the supporting structure (see Fig. 2). In the latter case, segments should be designed so that the vertical batten aligns with the gap between the cladding boards or battens, providing a place to fasten the wood screw. Furthermore, each segment joint must be aligned with an individual vertical batten (see Fig. 3).

To avoid damaging the boards when fastening, it is important to leave a gap of at least 8 mm between cladding segments (see Fig. 4).

Below, we present corner finishing solutions for cladding installed in segments (see Fig. 5;6).

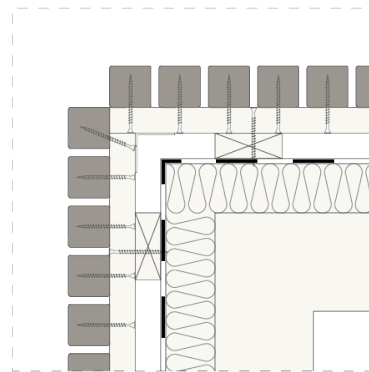

Fig. 5: External corner when installing cladding panels with non-grooved profiles

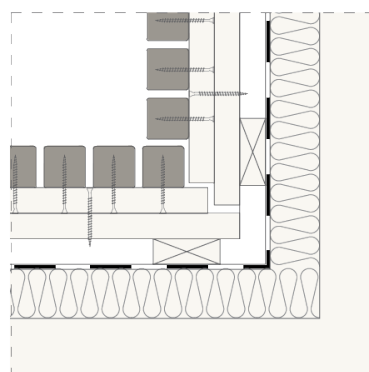
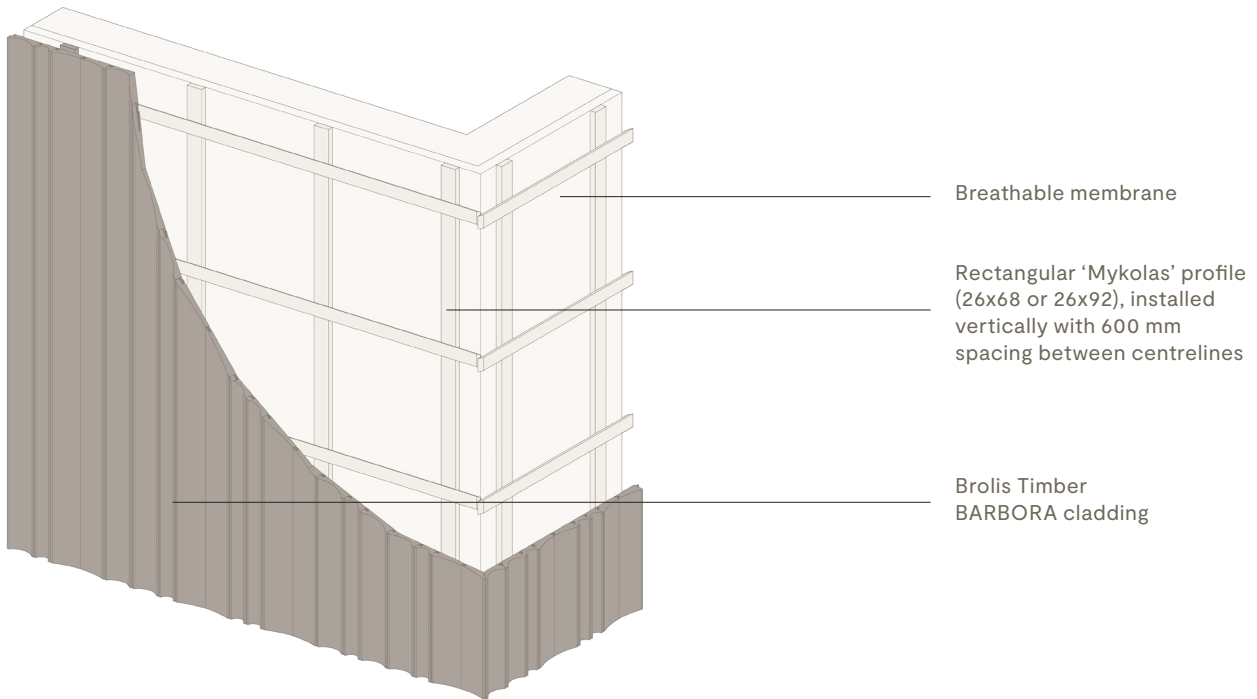

Fig. 6: Internal corner when installing cladding panels with non-grooved profiles



'Pasakų parkas' residential buildings // Vilnius, 2018 // Profile: batten 42x68 // Coating: clear WoodCream // Architects: Paleko architektų studija and KAParchitects // Photo: Norbert Tukaj

# BARBORA installation details



You can create a variety of façade patterns by combining 'Barbora' cladding boards of different widths. For outdoor use, vertical installation is recommended. For indoor use, the boards can be installed in any direction.

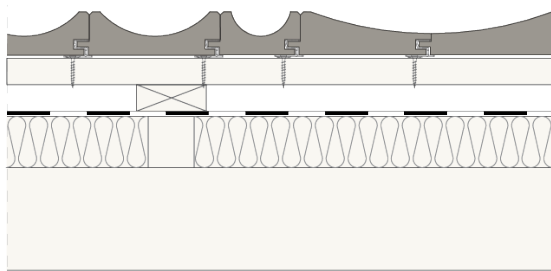

Barbora 42x92/42x140/42x140D ir 42x140K

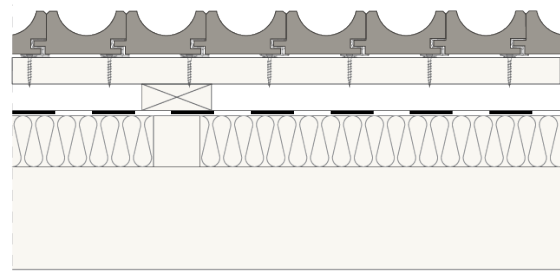

Barbora 42x92

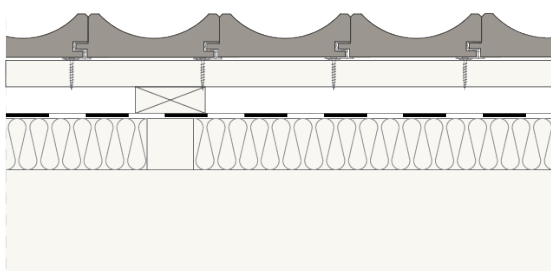

Barbora 42x140

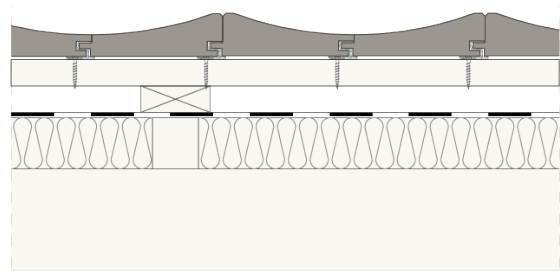

Barbora 42x140D ir 42x140K

# BARBORA installation details

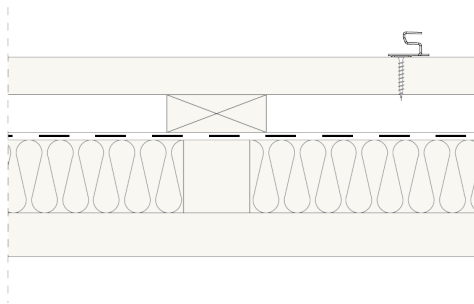

Fig. 1

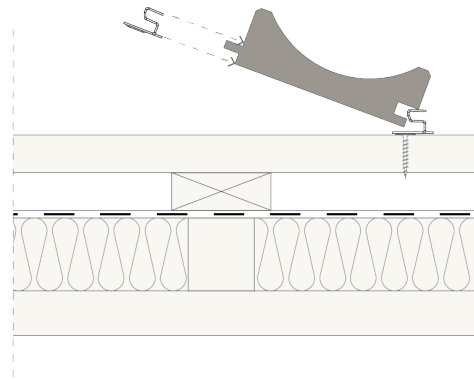

Fig. 2

After aligning the line using a laser or spirit level, attach the 'Dekora' clips in a vertical line (see Fig. 1). Before placing the 'Barbora' cladding board in position, insert the clip into the board's groove (see Fig. 2).

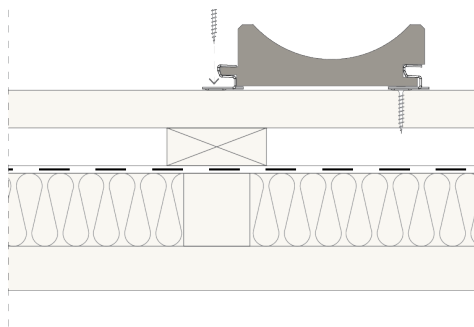

Fig. 3

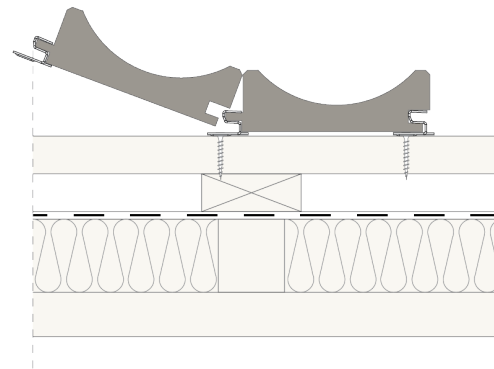
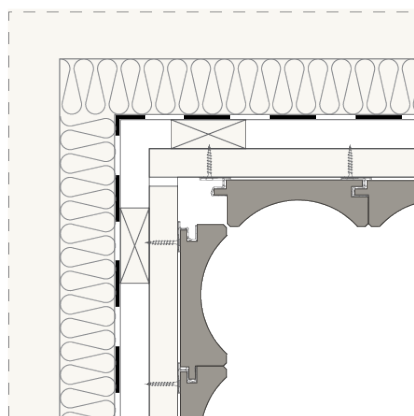
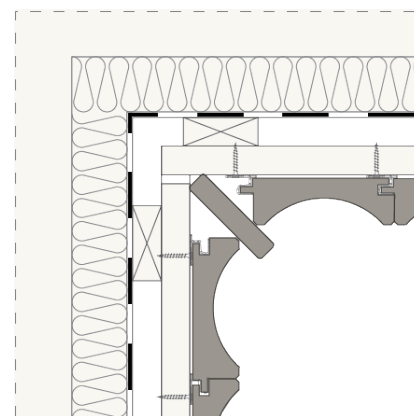

Fig. 4

Once 'Barbora' cladding boards are in place, fasten them with screws provided with the clips (see Fig.3). Attach the clips to each frame batten, spaced no more than 600 mm apart.



Pav. 5



Pav. 6

There is no need to cut the Barbora profile siding lengthwise when forming the inner corners. For a more aesthetically pleasing finish, connect the edges by pulling the cladding away from the corner by 42 mm (see Fig. 5). Alternatively, add an additional rectangular element (see Fig. 6).

# BARBORA installation details

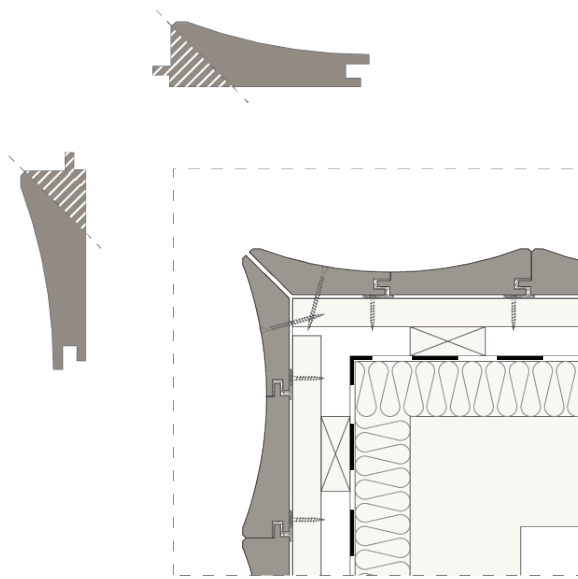

Fig. 1

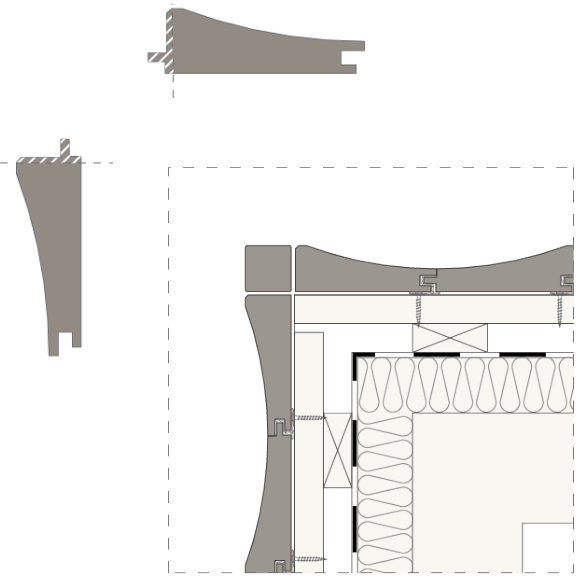

Fig. 2

When forming external corners, the edges of the ‚Barbora‘ cladding boards can be cut at a 45° angle and joined together (see Fig. 1). Alternatively, the grooved and tongued edges of both boards can be trimmed off and a 42 x 42 batten can be inserted (see Fig. 2). Make sure to leave a gap of at least 3 mm to for ventilation. Please note that the first method is not suitable for narrower 42x90 ‚Barbora‘ cladding boards.

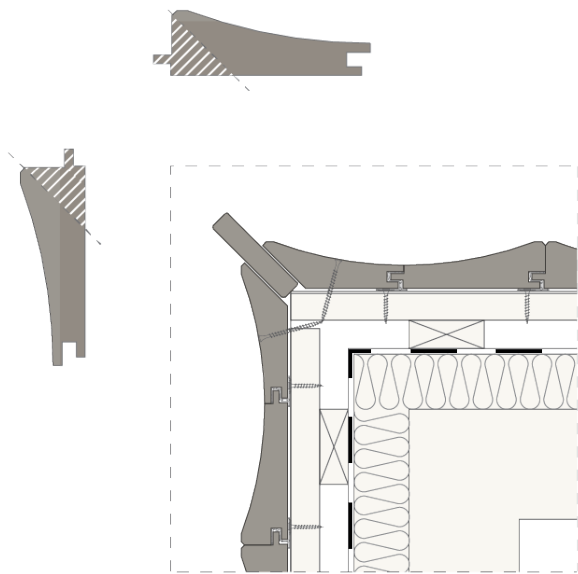

Fig. 3

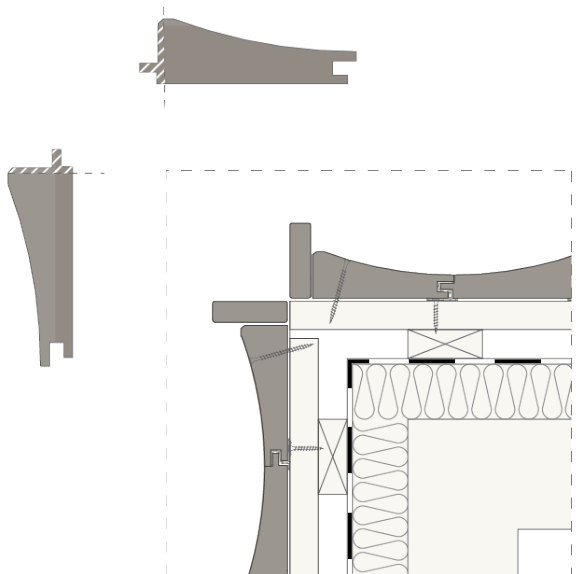

Fig. 4

To emphasise external corners when using Barbora cladding, board edges can be cut at a 45° angle and joined into a rectangular ‚Mykolas‘ 19x92 board (see Fig. 3). Alternatively, the tongue and groove edges of both boards can be trimmed off, and two ‚Mykolas‘ boards of the same profile can be inserted (see Fig. 4). Make sure to leave a gap of at least 3 mm to for ventilation

## 04.2 For horizontal cladding

# Board joining options

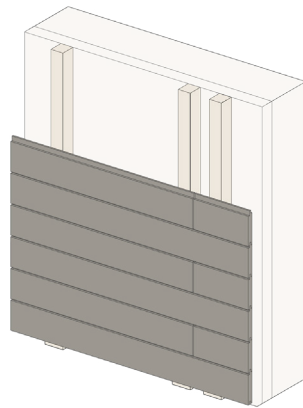

Fig. 1: Double vertical battens at cladding board joints

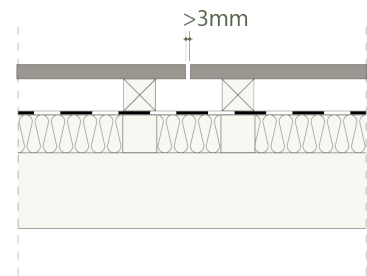

Fig. 2: Air cavity of at least 3 mm

General installation instructions described in the previous sections also apply to horizontal [ÜP14.1] cladding. Remember to install double vertical battens at board joints to provide proper support for cladding ends (see Fig. 1). Make sure to leave a gap of at least 3 mm to for ventilation (see Fig. 2).

When installing horizontal cladding, joints can be aligned in a straight line (see Fig. 3), arranged in a checkerboard pattern (see Fig. 4), or placed randomly.

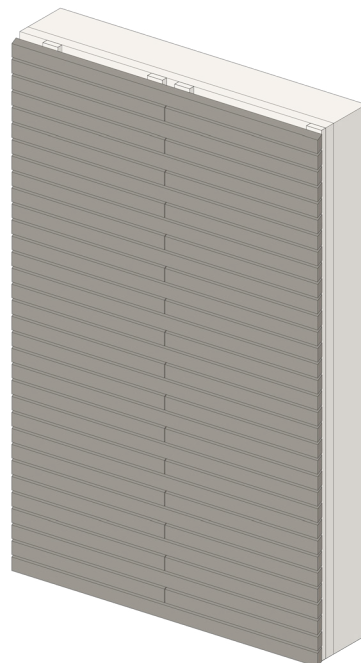

Fig. 3: Cladding joints aligned in a straight line

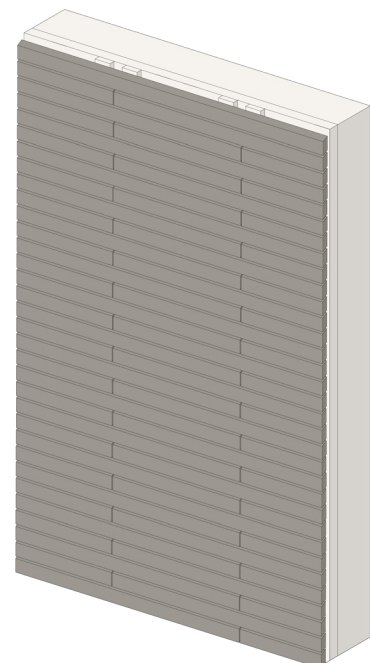
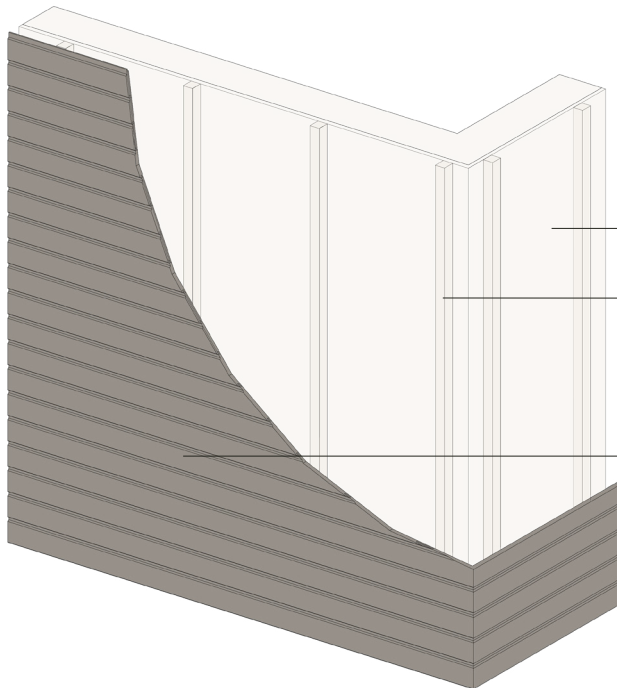

Fig. 4: Cladding joints arranged in a checkerboard pattern

# Grooved cladding details profiles

## Horizontal cladding, installed on a single-layer wooden subframe



Breathable membrane

Batten (42x42), installed vertically with 600 mm spacing between centrelines

Brolis Timber termo cladding

## Horizontal cladding, installed on a single-layer aluminium subframe

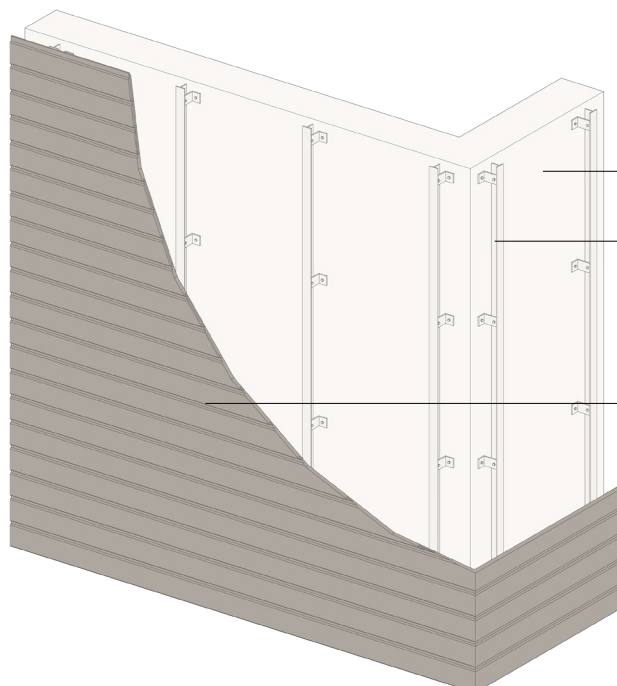

Breathable membrane

Aluminium T profile frame, installed vertically with 600 mm spacing between centrelines

Brolis Timber termo cladding

# Corner finishing with grooved profiles

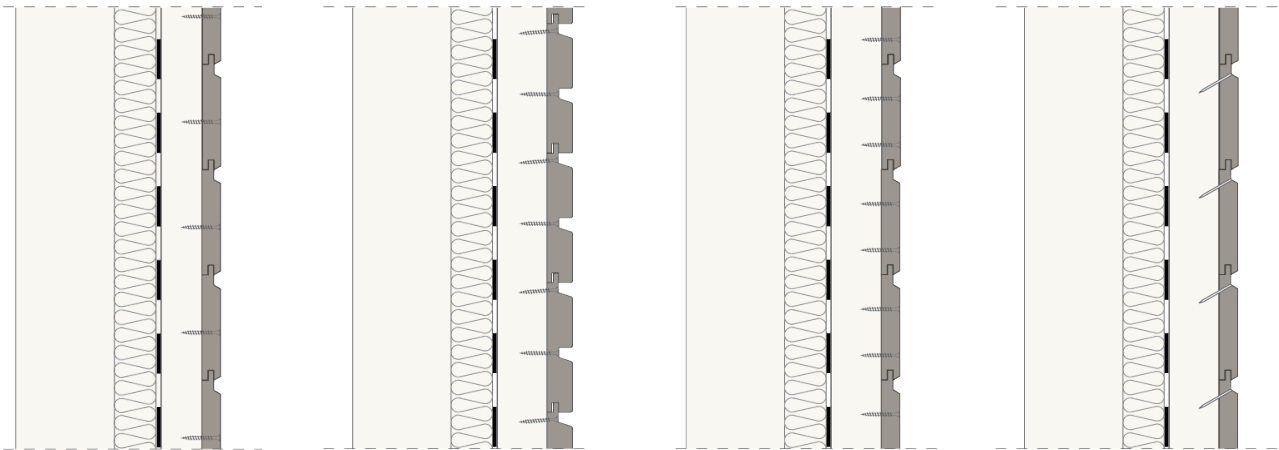

Cladding boards designed for horizontal installation always have a slope to ensure that precipitation does not accumulate on the wood surface and is drained off as quickly as possible.

Horizontal cladding boards are installed on a single-layer wooden frame. We recommend using battens that are 42 mm thick; however, if this is not possible due to design constraints, make sure to maintain an air cavity of at least 25 mm.

When using grooved profiles for horizontal cladding,

corners can be finished in the following ways:

- by cutting the board edges at a 45° angle (see Fig. 1)
- by covering the corner with two rectangular profiles joined at a 45° angle (see Fig. 2)
- by joining the boards edge-to-edge at the inner corner (see Fig. 3)

Make sure to leave a gap of at least 3 mm to for ventilation and wood movement when joining the boards (see Fig. 4).

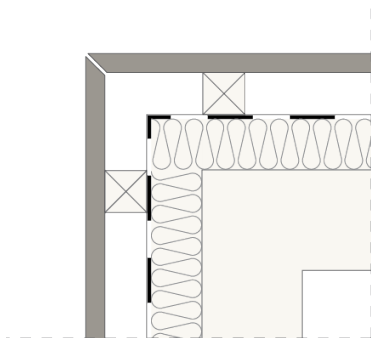

Fig. 1

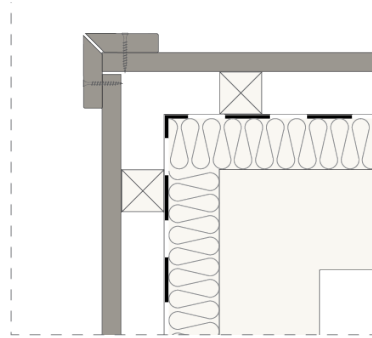

Fig. 2

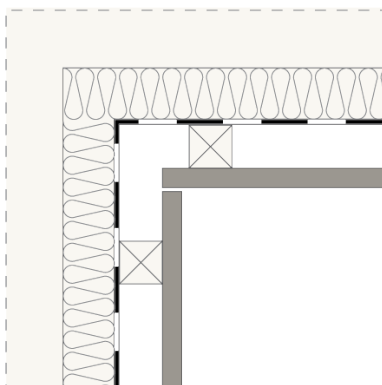

Fig. 3

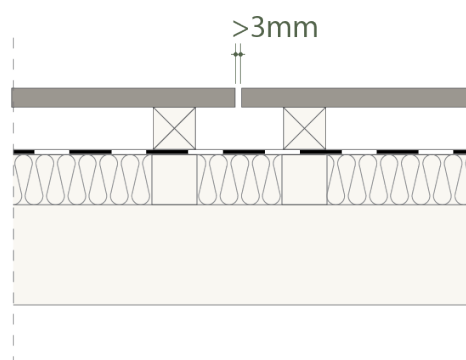

Fig. 4



Project 'Gervė' // Architects: Šilta šiaurė // Profile: Batten 42x42, Tikkurila Wood Stain 5083 //  
Rūta 19x117 Tikkurila Wood 5083 // Photo: Algirdas Bakas

# Non-grooved cladding details

## Horizontal cladding, installed on a single-layer wooden subframe

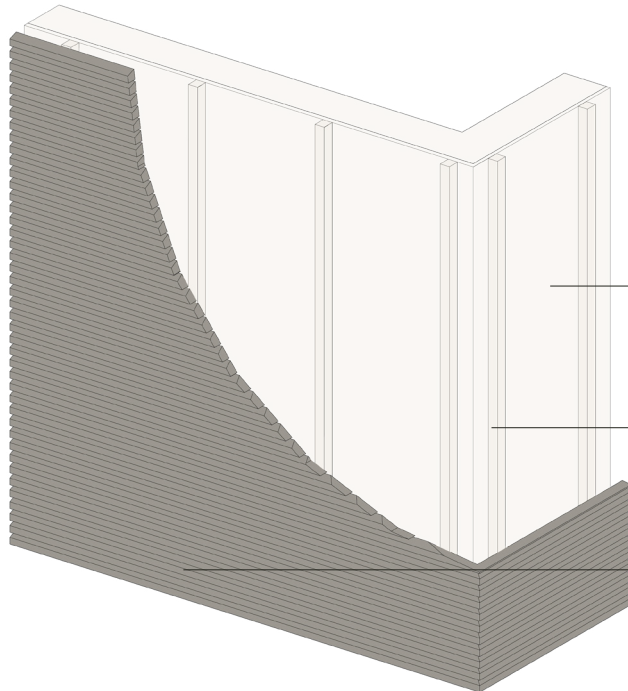

Breathable membrane. If cladding boards are installed with gaps that allow sunlight to pass through, the breathable membrane must be UV-resistant

Batten (42x42), installed vertically with 600 mm spacing between centrelines

Brolis Timber termo battens

## Horizontal cladding, installed on a single-layer aluminium subframe

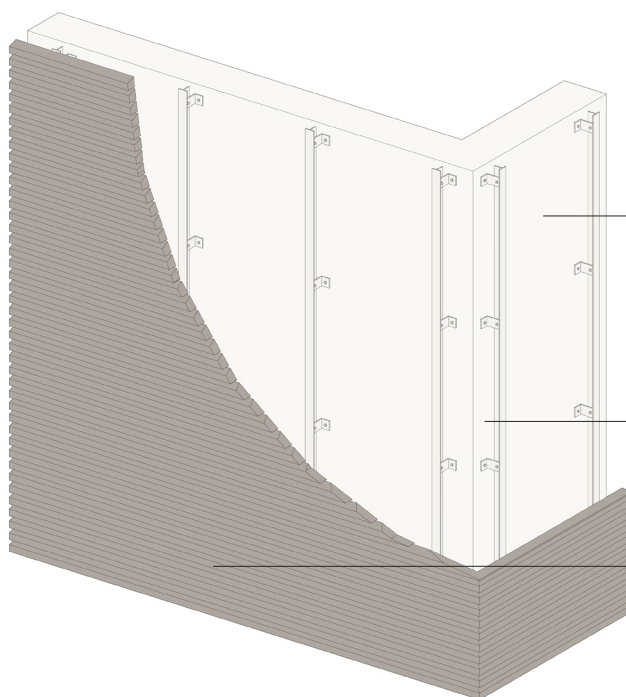

Breathable membrane. If cladding boards are installed with gaps that allow sunlight to pass through, the breathable membrane must be UV-resistant

Aluminium T profile frame, installed vertically with 600 mm spacing between centrelines

Brolis Timber termo battens

# Corner finishing with non-grooved profiles

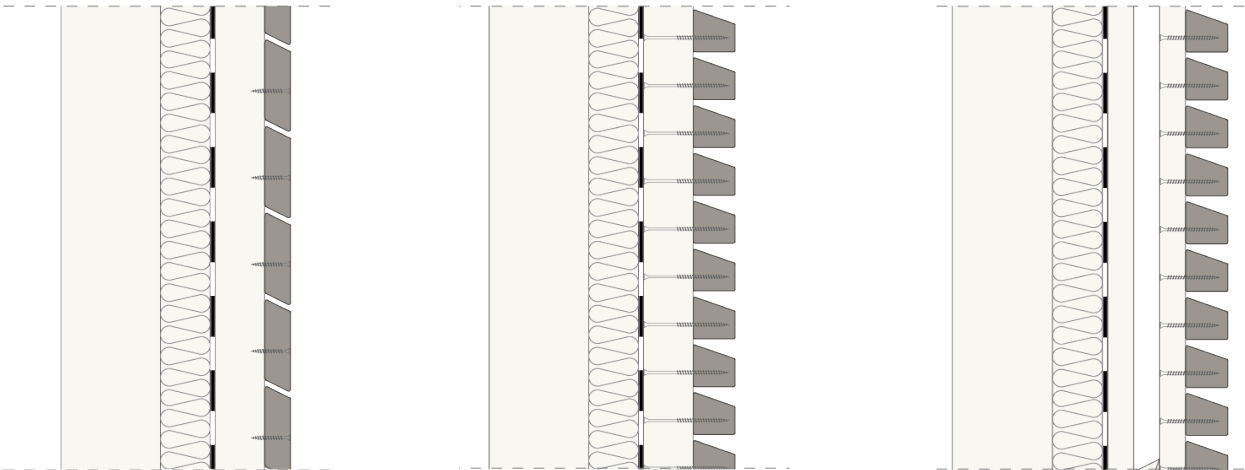

Fig. 1

Cladding boards designed for horizontal installation always have a slope to ensure that precipitation does not accumulate on the wood surface and is drained off as quickly as possible (see Fig. 1). Horizontal cladding boards are installed on a single-layer wooden frame. We recommend

using battens that are 42 mm thick; however, if this is not possible due to design constraints, make sure to maintain an air cavity of at least 25 mm. If cladding boards are installed with gaps that allow sunlight to pass through, the breathable membrane must be UV-resistant.

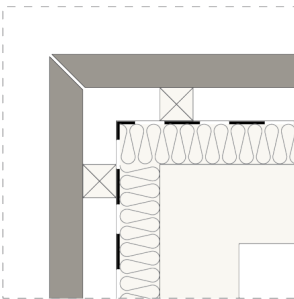

Fig. 2

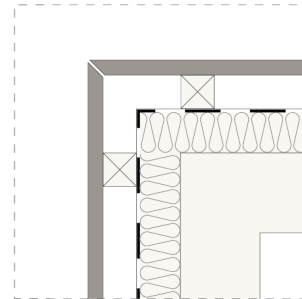

Fig. 3

When installing thermo cladding thicker than 26 mm, use vertical battens that are at least 42 mm thick.

When using non-grooved profiles for horizontal cladding, corners can be finished in the following ways:

- by cutting the board edges at a 45° angle (see Fig. 2; 3)

- by joining the boards edge-to-edge at the inner corner (see Fig. 4; 5)

Make sure to leave a gap of at least 3 mm for ventilation and wood movement when joining the boards.

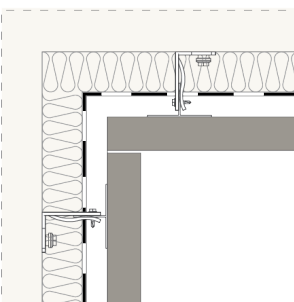

Fig. 4

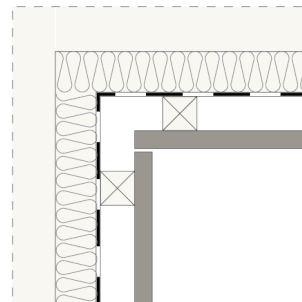

Fig. 5

# Opening edges design

Ensure that the chosen horizontal cladding profile is designed to prevent water accumulation (see Fig. 1).

Align the trim board covering the window reveal with the façade (see Fig. 2). Alternatively, the trim board can be extended slightly beyond the facade, creating a clean, graphic frame for the opening (see Fig. 3).

To form corners around openings, join cladding boards at a 45° angle and trim the edges and ends accordingly (see Fig. 4). Remember to leave a gap of at least 3 mm at the joints.

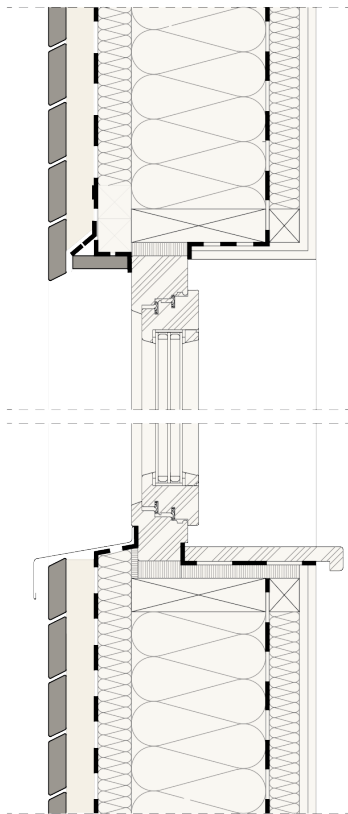

Fig. 1

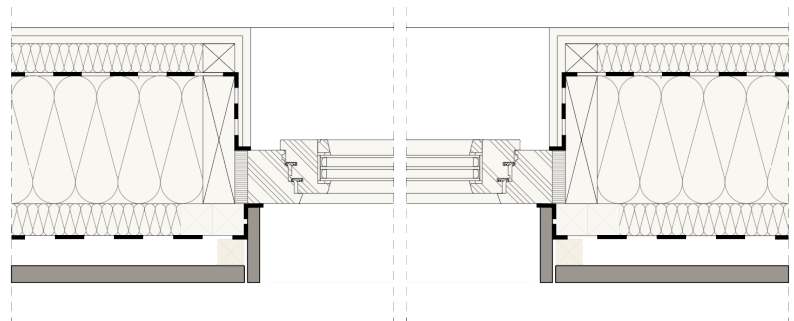

Fig. 2

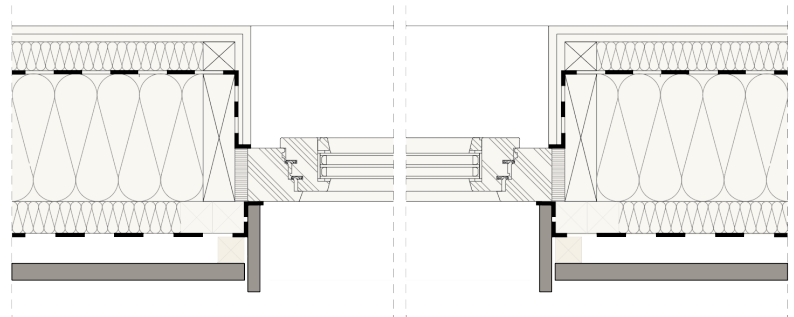

Fig. 3

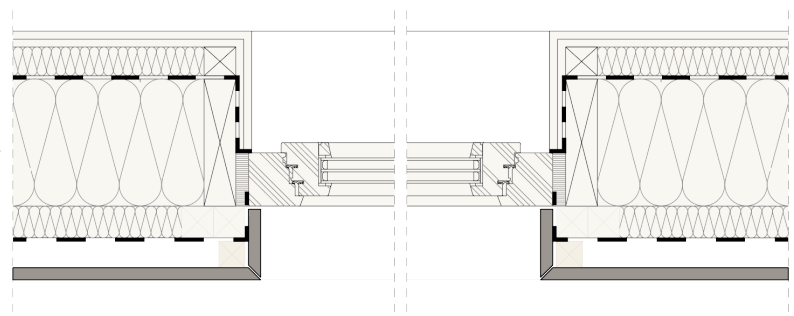

Fig. 4

## 04.3 Cladding patterns and design possibilities

# Mix and match

All \*Brolis cladding profiles are named and designed to connect seamlessly with each other, allowing you to create an array of textures and visual rhythms. Mix and match profiles freely to bring your ideas to life.

\*Except Barbora. Barbora does not combine with conventional profiles but fits perfectly into the authentic Royal family collection. Its hidden fastening system ensures a clean, modern aesthetic.

MAGDÉ



RŪTA



VAIVA



GRĒTĒ



URTĒ

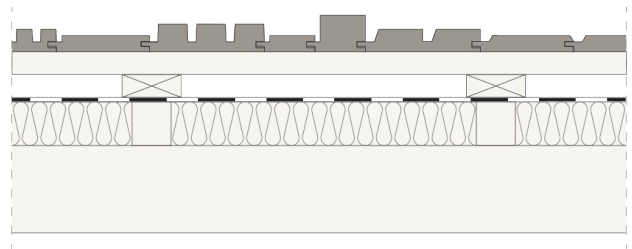
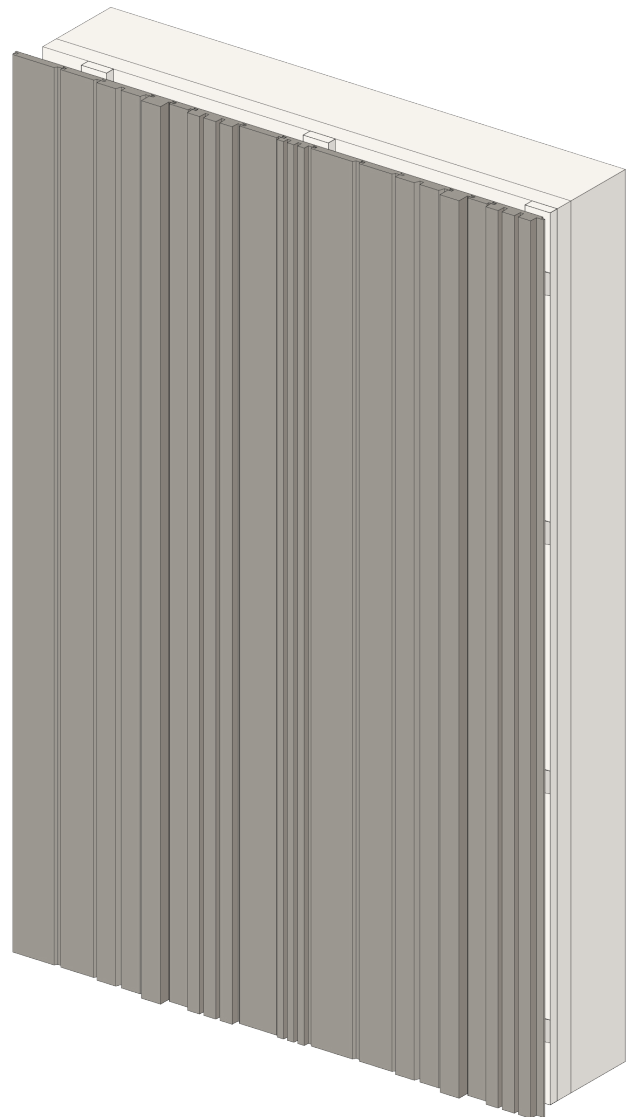
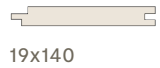

Fig. 1: All \* Brolis cladding profiles connect seamlessly with each other

# MAGDÉ family

## MAGDÉ



19x140



19x117



19x92



19x68



26x68



42x68

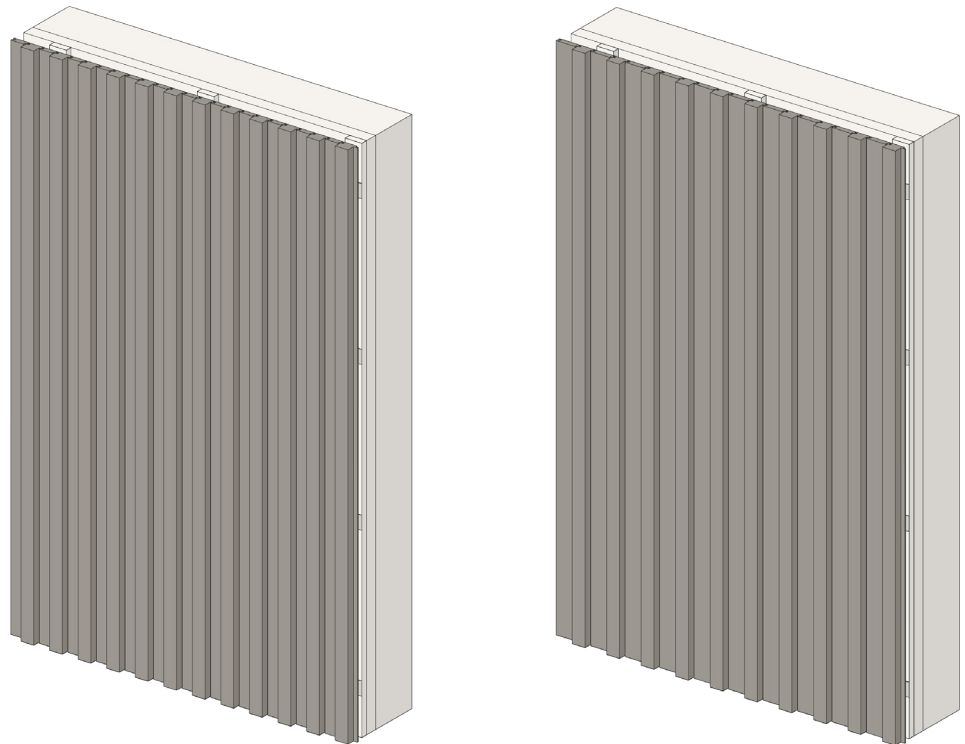

By combining Magdé profile cladding boards of various sizes, you can create expressive and dynamic façades. The system consists of four different board widths (19x68, 19x92, 19x117, and 19x140 mm) and battens in two thicknesses (26x68 and 42x68 mm). All boards and battens feature the same tongue-and-groove joint, ensuring full compatibility and seamless combinations.

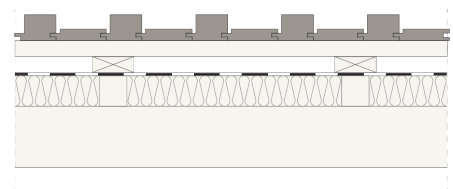
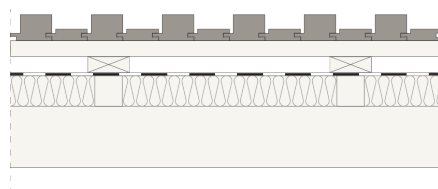

# MAGDÉ family

## MAGDÉ



19x140



19x117



19x92



19x68



26x68



42x68

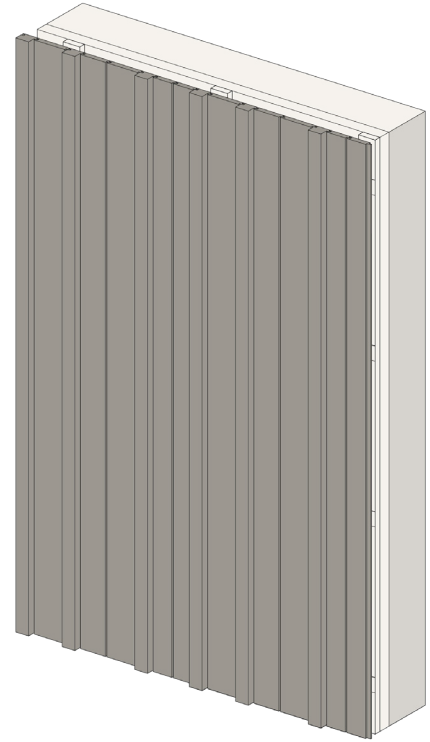
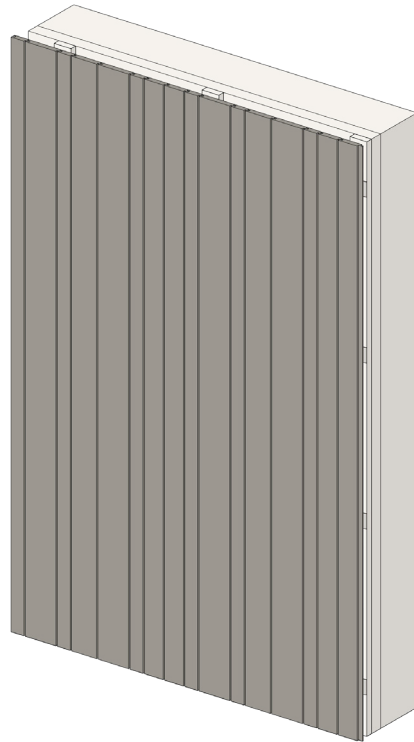

Brolis Magdé family cladding boards can be installed in a random pattern or following a specific rhythm. The required quantity of materials is calculated either as a share or by units based on the repeating segment.

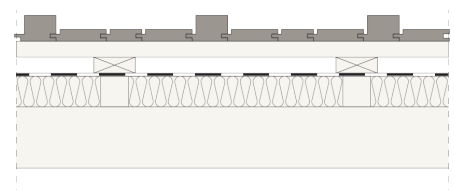
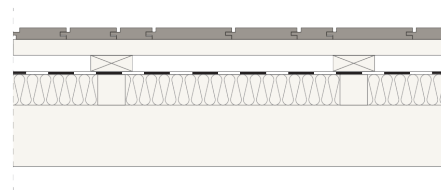

# MAGDÉ family

## MAGDÉ



19x140



19x117



19x92



19x68



26x68



42x68

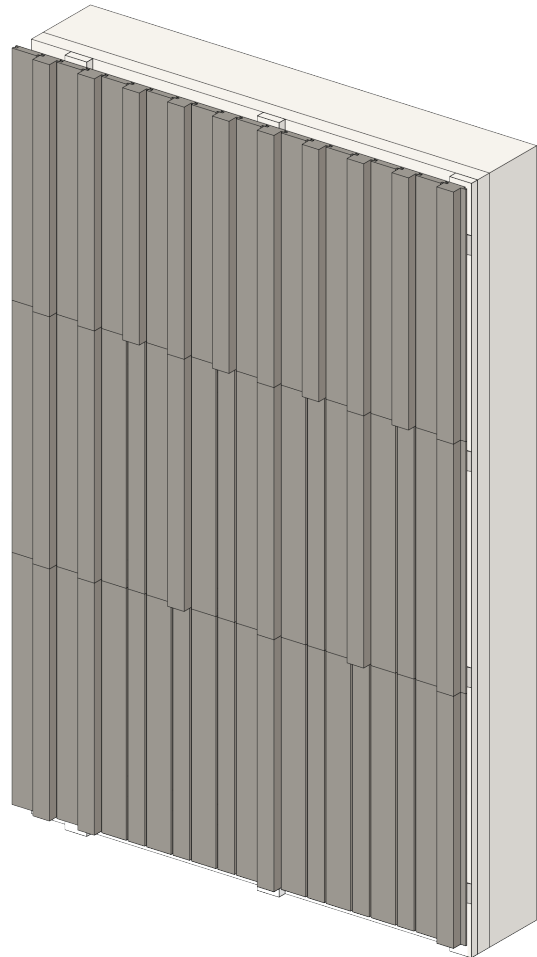

The façade pattern can be altered by splitting it vertically. When joining cladding boards vertically, the ends must be cut at a minimum 30° angle.

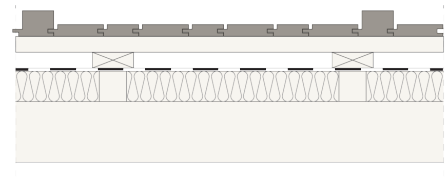
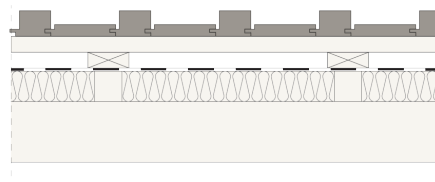

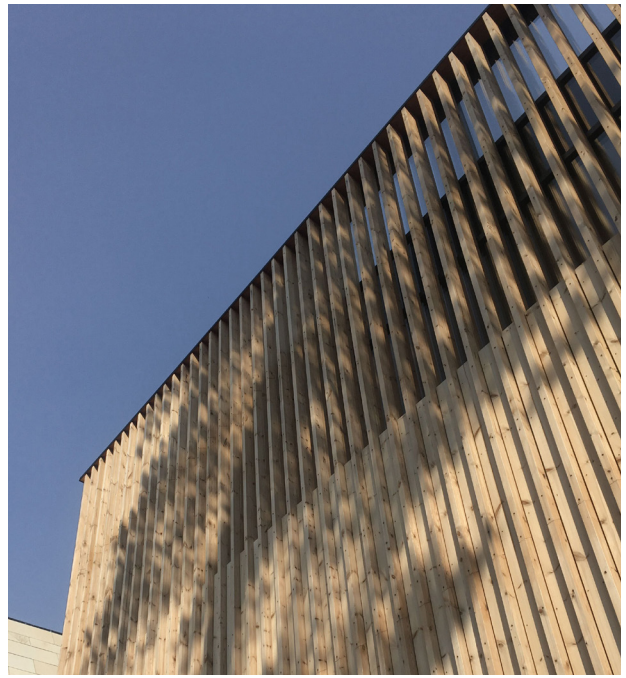

Family villa in Giruliai // Giruliai, 2019 // Profiles: Battens (42x42, 42x68, 42x92) coated in clear oil, terrace Jonas (26x117) // Architects: DO ARCHITECTS (Andr  Baldi iut , Algimantas Neni kis, Julija  iapait  – Jurevi ien , Kasparas  iliukas) // Photos: Laimonas Ci unys, DO ARCHITECTS

# MYKOLAS family

## MYKOLAS



19x140



19x117



19x92



19x68

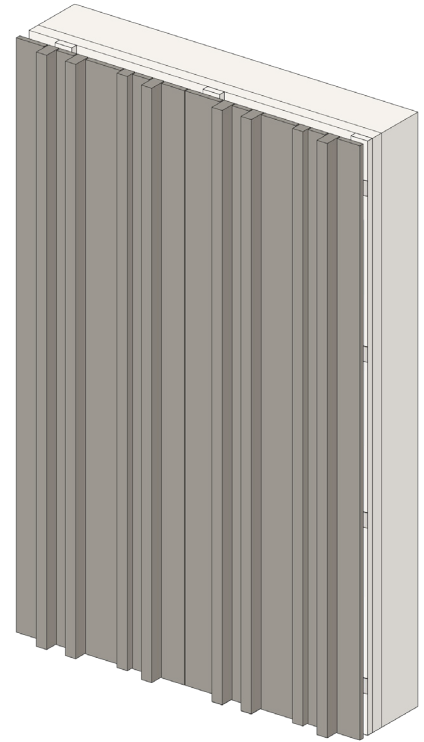
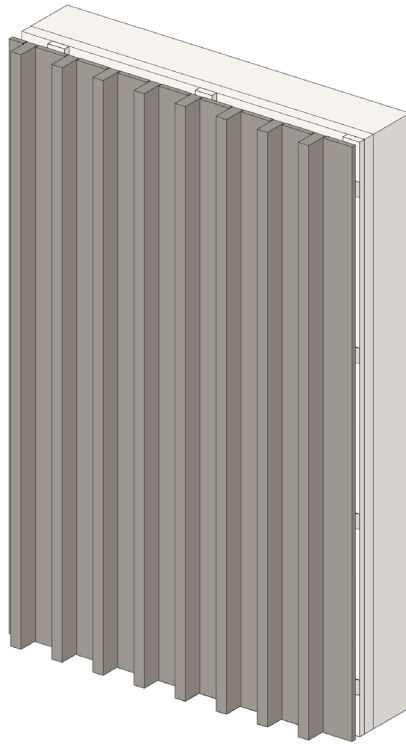

Expressive and dynamic facades can also be created by mixing non-grooved cladding boards and battens.

Please note that, when installing battens larger than 42x42 mm, horizontal frame battens should be at least 42 mm thick.

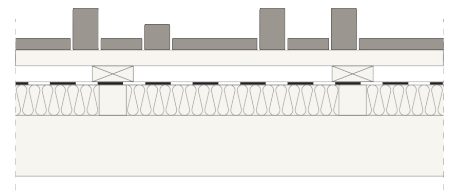
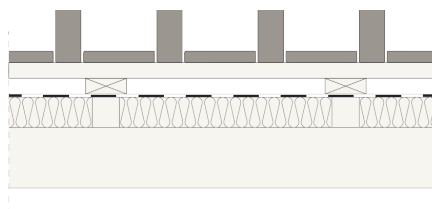

# MYKOLAS family

## MYKOLAS



19x140



19x117



19x92



19x68

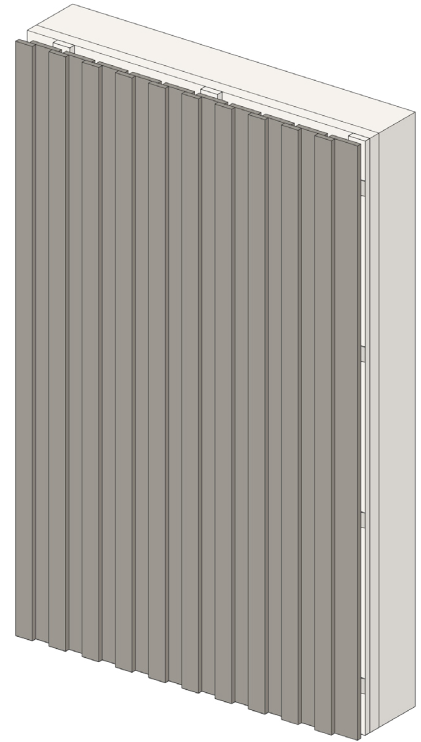
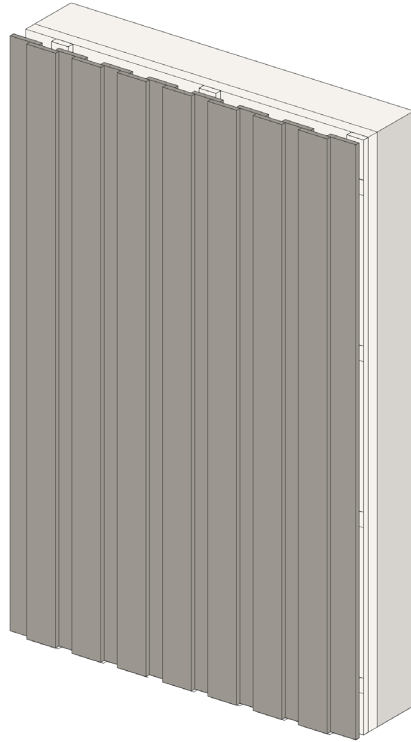

You can achieve a three-dimensional façade effect with just one type of cladding boards by installing them with an overlap. Ensure that the overlap is at least 20 mm.

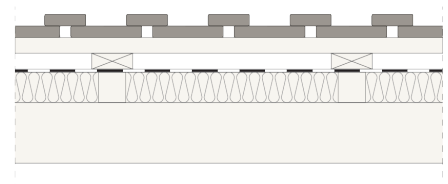
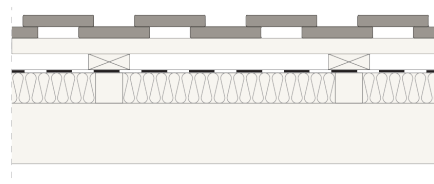



DO ARCHITECTS, Svencelės salos // Profiles: Mykolas (19x92, 19x117, 26x68, 42x92, 42x140) coated in black Tikukurila Wood Stain 5089, terrace Mykolas (26x117) not coated // Architects: DO ARCHITECTS, Karresen Brand (master plan) // Photos: DO ARCHITECTS, Svencelės salos



Residential building in Gulbinai // Vilnius, 2020 // Profiles: Rombas (20x92), Mykolas (26x68) //  
Coating: Teknos 1707 // Architects: 2XJ // Photos: Norbert Tukaj

# Wood shingles

## MYKOLAS



19x140



19x92



19x117



19x68

Brolis Timber thermo cladding boards can be installed using the shingle method. Each board must be fastened to two horizontal battens. Variety of board sizes and joint types allows for different patterns and visual effects (see Fig. 1, 2, 3).

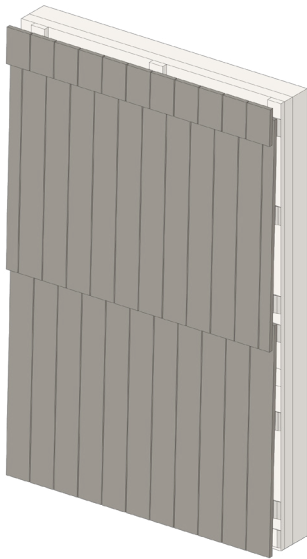

Fig. 1: Cladding boards overlapped by 5%

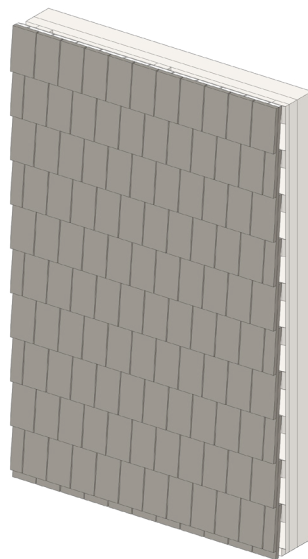

Fig. 2: Cladding boards overlapped by 50%

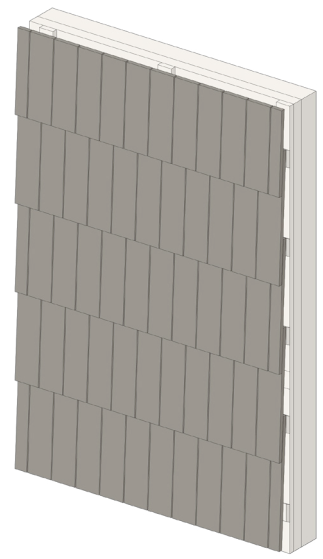
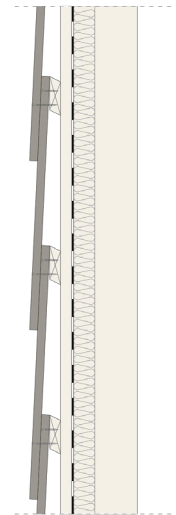
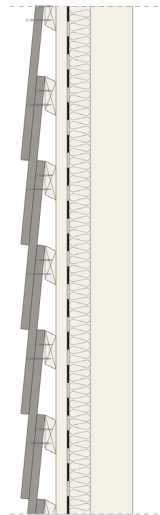
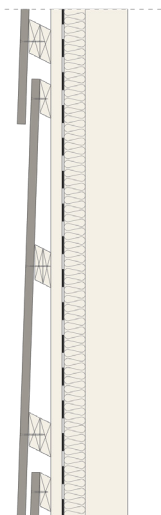

Fig. 3: Cladding boards overlapped by 30%



05

# Coating and Ageing

# Outdoor conditions

Brolis thermos timber, like all other wood, gradually turns grey when exposed to UV rays. The more sunlight, the faster this change occurs.

Rain and humidity are the main factors affecting the durability and appearance of wooden façades. Water that remains on the surface accelerates the ageing process of thermo timber and causes discolouration. Areas of the façade that are exposed to more water or have poor ventilation tend to darken over time. Therefore, when

designing the building, it is important to consider the average precipitation in the area and identify where moisture may accumulate. Proper drainage and rain-water management systems must be installed, along with adequate façade ventilation.

Direct sunlight also affects the appearance of thermo timber. South-facing façades lose their caramel hue more quickly and fade unevenly compared to those facing north.

## Annual precipitation (mm)

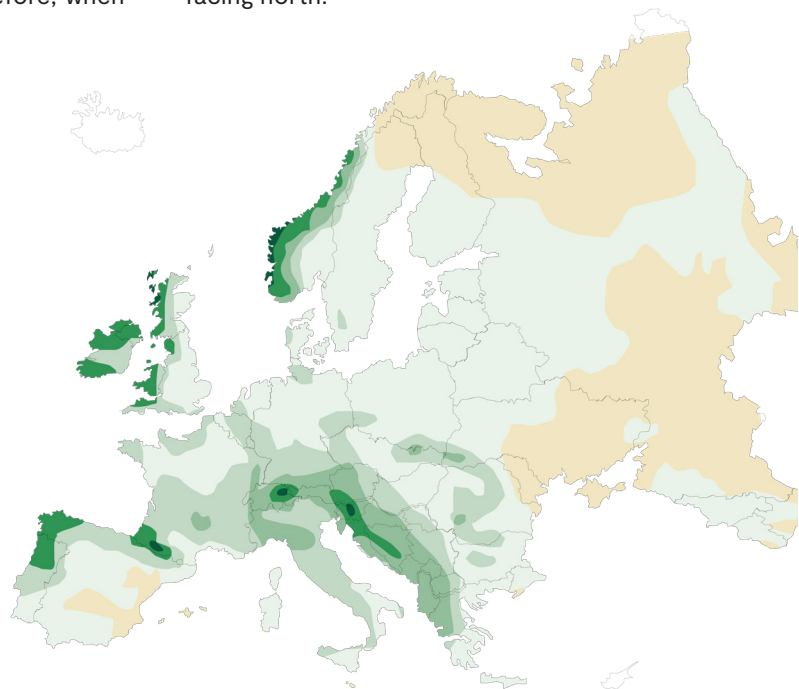
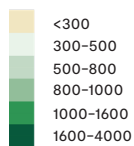

## Annual sunshine hours

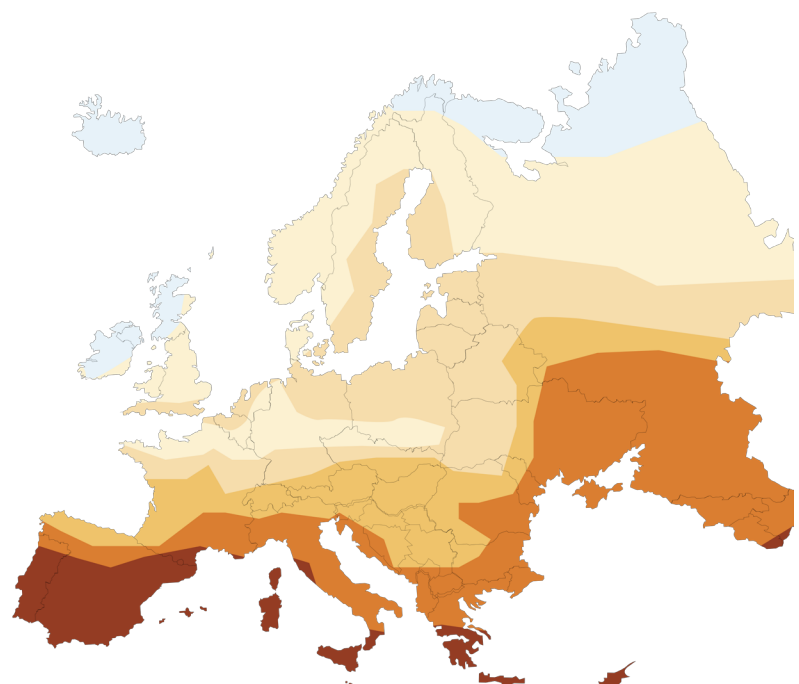
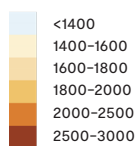

# Ageing

Fresh thermally treated wood has a caramel hue but gradually turns grey when exposed to outdoor conditions. This is a natural process caused by UV radiation that affects all wood types. The colour changes – from silvery to almost black – are influenced by surrounding vegetation and microfauna, the amount of pollen and dust, wind, precipitation, as well as various combinations of these factors.

Over time, cracks may appear on the surface of thermo-treated wood when exposed to outdoor conditions. However, since the wood is thermally modified all the way through, these changes have no significant impact on its durability. Such changes are purely aesthetic and do not affect the functional properties of thermo timber.

Thermo timber turns grey at different rates across a façade due to uneven sunlight exposure. North-facing walls typically grey the most evenly. Architectural features like eaves, window reveals, and other shaded areas tend to age differently (see Fig. 1). Even the direction of the cladding has an impact – vertical boards usually grey more uniformly.

Given the wide range of influencing factors and their combinations, it is impossible to predict exactly how long it will take for an untreated thermo façade to turn grey. However, the colour begins to change immediately after installation, and visible changes typically appear within the first 3 to 6 months. While greying is a continuous process, the longer the timber remains on the façade, the less noticeable the changes become.

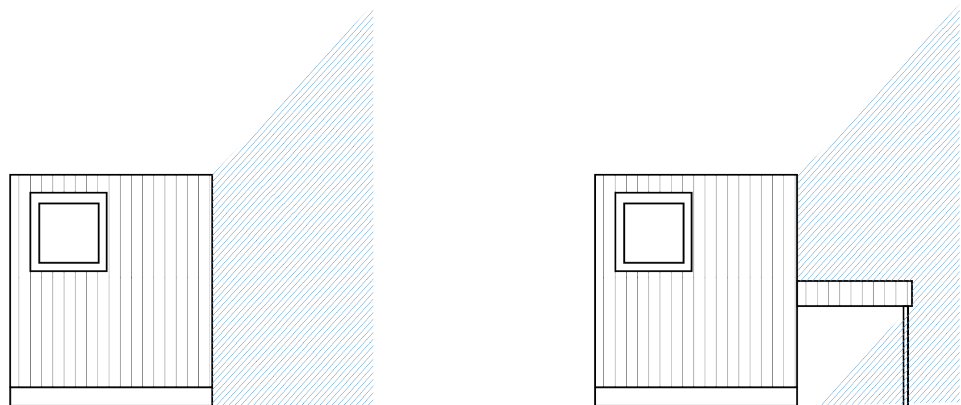

Fig. 1: The impact of building architecture on changes in façade colour. Surfaces not exposed to direct sunlight retain their brown colour, therefore shaded areas turn grey much more slowly.



Menų inkubatorius Rupert // Vilnius, 2013 // Profiles: Mykolas (19x117) // Not coated // Architects: Ambraso architektų biuras // Photos: Norbert Tukaj



Menų inkubatorius Rupert // Vilnius, 2013 // Profiles: Mykolas (19x117) // Not coated // Architects: Ambraso architektų biuras // Photos: Norbert Tukaj

# Coating

Thermo cladding can be coated with wood-specific products, just like regular cladding\*. The most important requirement is that the chosen coating allows the wood to „breathe” — in other words, it must allow moisture to evaporate. Pigmented products protect the surface from UV rays and slow down the ageing process. Please note that transparent finishes do not prevent the timber from turning grey.

Due to the exceptional durability of Brolis thermo timber, no additional antiseptic treatment is required. The main purpose of coating is to create or maintain the desired aesthetic, which is why we recommend sustainable, environmentally friendly solutions only.

Brolis timber cladding boards can be textured and factory-coated to ensure an even, technologically precise finish. Due to the smooth, knot-free surface of thermos

timber, coatings last significantly longer and look far more refined and luxurious. The entire colour spectrum looks beautiful — from deep charcoal black to subtle greenish, greyish, or even bleached tones.

These finishes offer an exceptional aesthetic variety for your inspiring projects.

Over time, coated cladding may need to be refreshed, depending on the wear and coating manufacturer’s recommendations. The finishes we use do not require sanding – simply clean the surface with an alkaline wood cleaner to remove any build-up, then apply an additional layer of stain or paint.

\* We do not recommend using linseed oil, as it encourages the formation of surface mould.



12 Bičiulių kvartalas // 2023 // Profiles: Mykolas (15x92), brushed // Coating: 5089 // Architects: Dovydas Čipkus (MB “Mes Architektai”) // Photos: Gabrielius Lenksas



Birštonas // 2022 // Profiles: Urtė (16x142) // Coating: Tikkurila 5071 // Architects: "Kubinis metras" // Photos: A. Garbačiauskas // Developer: "Sluoksnis"



# Coating and maintenance options

Taking into account environmental factors, architectural design and personal preferences, we offer several different scenarios to help you decide on the coating and maintenance of the façade:

## 01 **Not coated**

Due to the inherent durability of thermo timber, cladding can be left uncoated. Over time, it naturally weathers to grey, depending on environmental conditions and architectural features. Uncoated façades require no maintenance and take on a natural, evolving appearance — from warm caramel tones in shaded areas to grey or even black in areas exposed to moisture and buildup.

## 02 **Coated**

To preserve the original caramel tone of thermo timber, the cladding can be coated with a pigmented stain in a similar colour. The pigment protects the surface from UV rays and helps prevent greying. Depending on environmental conditions, the stain used by Brolis Timber lasts 3 to 6 years on façades. Over time, the colour fades as the pigment gradually wears off. To refresh the finish, the façade should be cleaned with an alkaline wood cleaner and re-coated.

## 03 **Greyed**

If you like the look of greyed thermo timber, but don't want an uneven greying process, we recommend texturing the cladding surface — thus enhancing the effect of weathered wood — and using a stain in a greyish tone. As the pigment gradually wears off, exposed areas will grey naturally, helping the façade retain a cohesive look.

Any chosen colour or finish holds much better and looks significantly more refined on the smooth, dry surface of thermo timber. Tree resin does not seep through. The full spectrum of colours — from deep charcoal to soft greens, greys or even bleached tones — looks great. Due to the dimensional stability of the boards, the clean, modern lines of the façade remain sharp even after many years. These finishes offer an exceptional aesthetic variety for your most inspiring projects.

# Storage

Although Brolis thermo timber is naturally more resistant to moisture and deformation than regular wood, proper storage practices must be followed to preserve product quality and avoid damage or warping.

Store cladding boards in a dry, well-ventilated area, protected from direct sunlight and precipitation. Place them on aligned bearers, not directly on the ground. Ensure proper air circulation underneath.

Before work begins, thermo timber can be stored outside temporarily, as long as it is adequately shielded from UV exposure, rain, and snow. Usually, wood packages are wrapped with waterproof sheeting that covers the top and sides to protect the board ends from greying,

while keeping the bottom open to ensure air circulation.

However, we recommend installing the products as soon as possible to avoid prolonged storage. Outdoors, especially on construction sites, wood packages are often exposed not only to moisture but also to dust and pollen. This creates ideal conditions for surface mould to develop inside covered packages. Consequently, mould may appear while the wood is still packaged or shortly after installation.

When transporting, avoid bending, impacts or pulling from one end only. Use edge protectors. Lift the boards at multiple points to evenly distribute the weight along their length.

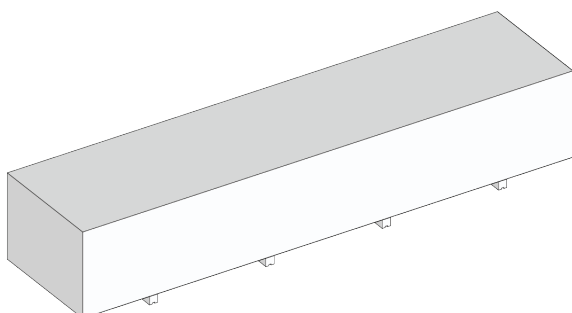
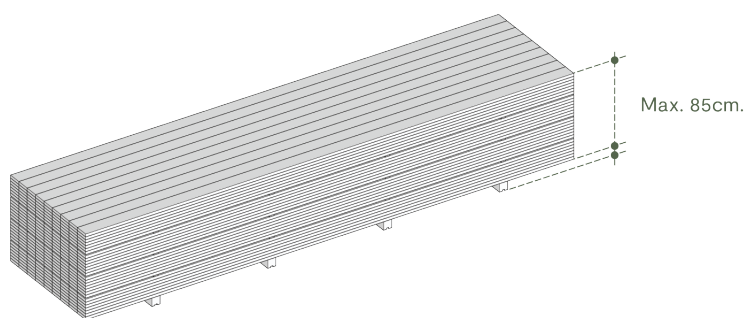
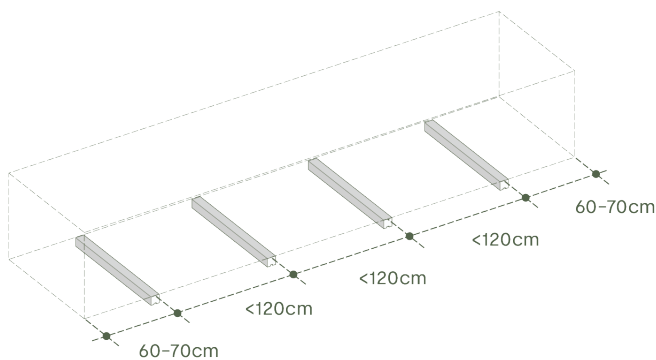

# Limitation of liability

## **Product characteristics**

Brolis thermos timber is a natural material. Due to its organic origin, each board is slightly different – variations in colour, texture, weight, and knot placement may occur. Although thermal modification significantly reduces timber movement, it does not eliminate it completely. As a result, the wood still responds to environment: it may slightly expand or contract, and cracks or splinters might appear. These natural changes are not considered manufacturing defects.

## **Installation and maintenance**

During thermo timber storage, installation, and maintenance, it is essential to follow Brolis Timber technical guidelines provided in this document or available on our website.

We cannot be held responsible for any undesired changes in quality if the timber is stored, installed, or maintained in a way that does not align with our recommendations.

Thermo timber is not intended for structural applications, as it is more brittle and less flexible than unmodified wood.

We recommend following local building regulations and codes. For façades and other exterior applications, always consult with your architect, structural engineer, or construction professional.

## **Maintenance**

If left uncoated, thermo timber will gradually change colour over time. This is only a visual transformation and does not affect the durability of the wood. More information can be found in the 'Coating and Ageing' section on page 68 of this document.

To preserve the original colour, use an oil with UV protection.

It is recommended to inspect the façade annually by checking the fixing points and timber surface. If needed, clean the surface or renew the finish according to the guidelines provided in this document.

Do not use high-pressure washers, as they can damage the surface and cause splintering.

## **Manufacturer's responsibility**

The manufacturer is only responsible for production quality issues. We do not accept liability if the product has been used or installed in a way that goes against the instructions provided.

Changes in colour, cracks or surface ageing caused by natural factors such as rain, UV exposure and pollution are not considered defects. Mechanical defects that occur during transportation, installation, or use are not manufacturer's responsibility, except in cases when transportation is carried out by Brolis Timber.

Boards that do not meet the specified quality grade must not be cut or used in any other way. Until they have been assessed, products should be stored raised off the ground on a flat surface and protected from UV exposure. Failure to comply with these instructions will invalidate the replacement warranty.

### **Information and consultation**

You're always welcome to reach out to us. We're here to help you avoid mistakes and achieve the best possible results with our thermo timber products. You can find our contact details on our website, [www.brolistimber.lt](http://www.brolistimber.lt), or email us at [info@brolis.eu](mailto:info@brolis.eu).

### **Copyright and usage rights**

This entire document, including all text and graphic elements, is the property of Brolis Timber. Copying, distributing or using this material for commercial purposes without prior written permission is strictly prohibited.

### **Note**

This information is provided without legal obligation and may be subject to change without prior notice. All previous versions of these installation guidelines are considered void.



Project Nardinai (Lewben Art Foundation) // Vilnius, 2022 // Profiles: Batten (42x140), B grade // Not coated // Architects: Vladas Suncovas // Photos: Rytis Šeškaitis



Brolis  
Timber